

**2x20A
Compact
High Performance
Dual Channel
Forward/Reverse
Brushed DC Motor
Controller with USB**

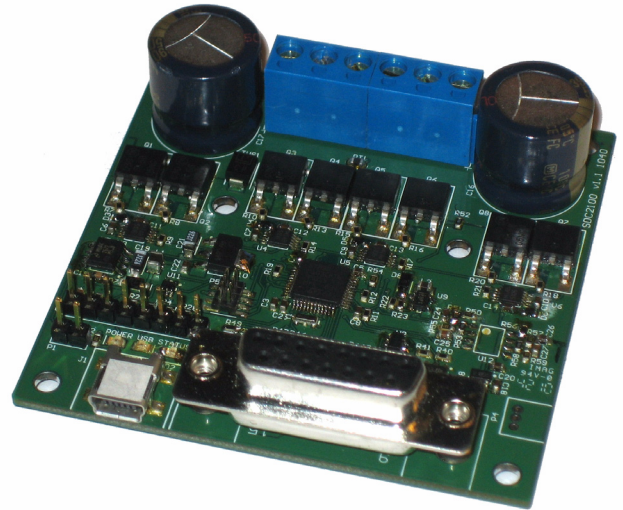

Roboteq's SDC2130 (30V) / SDC2150 (50V) controller is designed to convert commands received from an RC radio, Analog Joystick, wireless modem, PC (via RS232 or USB) or microcomputer into high voltage and high current output for driving one or two DC motors. Fitting a very compact 70x70mm board, and designed for maximal ease-of-use, it is delivered with all necessary cables and hardware, and is ready to use in minutes.

The controller features a high-performance 32-bit microcomputer and quadrature encoder inputs to perform advanced motion control algorithms in Open Loop or Close Loop (Speed or Position) modes. The SDC2130/SDC2150 features several Analog, Pulse and Digital I/Os which can be remapped as command or feedback inputs, limit switches, or many other functions.

For mobile robot applications, the controller's two motor channels can either be operated independently or mixed to set the direction and rotation of a vehicle by coordinating the motion of each motor. Numerous safety features are incorporated into the controller to ensure reliable and safe operation. The controller's operation can be extensively automated and customized using Basic Language user programs. The controller can be reprogrammed in the field with the latest features by downloading new operating software from Roboteq.

Applications

- Industrial Automation
- Tracking, Pan & Tilt systems
- Small to mid-size Terrestrial and Underwater Robotic Vehicles
- Automatic Guided Vehicles
- Automated machines
- Telepresence Systems
- Animatronics

Features List

- USB, RS232, 0-5V Analog, or Pulse (RC radio) command modes
- Auto switch between USB, RS232 (12V levels or non-inverted TTL levels), Analog, or Pulse based on user-defined priority
- Input for direct connection to Spektrum digital RC radios
- Built-in high-power power drivers for two brushed DC motors at up to 20A output per channel
- Full forward & reverse control on each channel. Four quadrant operation. Supports regeneration
- Operates from a single 10V-35V (SDC2130) or 10V-50V (SDC2150) power source
- Programmable current limit for each channel up to 2x20A for protecting controller, motors, wiring and battery.
- Up to 4 Analog Inputs for use as command and/or feedback
- Up to 5 Pulse Length, Duty Cycle or Frequency Inputs for use as command and/or feedback
- Up to 6 Digital Inputs for use as Deadman Switch, Limit Switch, Emergency stop or user inputs
- Dual Quadrature Encoder inputs with 32-bit counters
- 2 general purpose 24V, 1A output for brake release or accessories
- Selectable min, max, center and deadband in Pulse and Analog modes
- Selectable exponentiation factors for each command inputs
- Trigger action if Analog, Pulse or Encoder capture are outside user selectable range (soft limit switches)
- Open loop or closed loop speed control operation
- Closed loop position control with analog or pulse/frequency feedback

- Precise speed and position control when Encoder feedback is used
- PID control loop with separate gains for each channel
- Optional Mixed control (sum and difference) for tank-like steering
- Configurable Data Logging of operating parameters on RS232 Output for telemetry or analysis
- Built-in Battery Voltage and Temperature sensors
- Power Control header for turning On or Off the controller from external microcomputer or switch
- No consumption by output stage when motors stopped
- Regulated 5V output for powering Encoders, RC radio, RF Modem or microcomputer
- Separate Programmable acceleration and deceleration for each motor
- Separate Programmable maximum forward and reverse power
- Direct connection to multi-channel Spektrum-brand 2.4GHz RC receiver
- Ultra-efficient 10 mOhm ON resistance MOSFETs
- Orderable as single channel version up to 40A
- Stall detection and selectable triggered action if Amps is outside user-selected range
- 10 to 32kHz user programmable Pulse Width Modulation (PWM) output.
- Overvoltage and Undervoltage protection
- Programmable Watchdog for automatic motor shutdown in case of command loss
- Overtemperature protection
- Diagnostic LED
- Efficient heat sinking using conduction bottom plate. Operates without a fan in most applications.
- Power wiring via terminal strip wires up to AWG12
- 2.76" (70mm) L, 2.76" W (70mm), 0.78" (20mm) H
- -40o to +85o C operating environment
- 3.5oz (100g)
- Easy configuration, tuning and monitory using provided PC utility
- Field upgradeable software for installing latest features via the internet

Orderable Product References

TABLE 1.

Reference	Number of Channels	Amps/Channel	Volts
SDC2130	2	20	30V
SDC2150	2	20	50V

Power Wires Identifications and Connection

Power connections are made through a 6 position screw terminal.

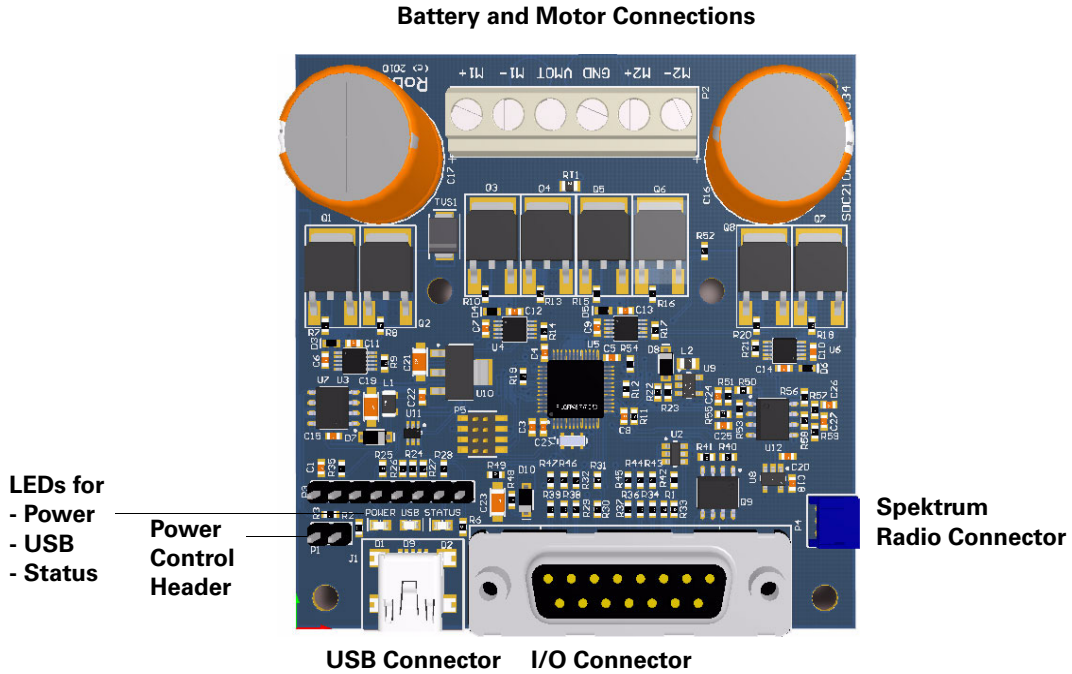

FIGURE 8. Controller layout

The diagram below shows how to wire the controller and how to turn power On and Off.

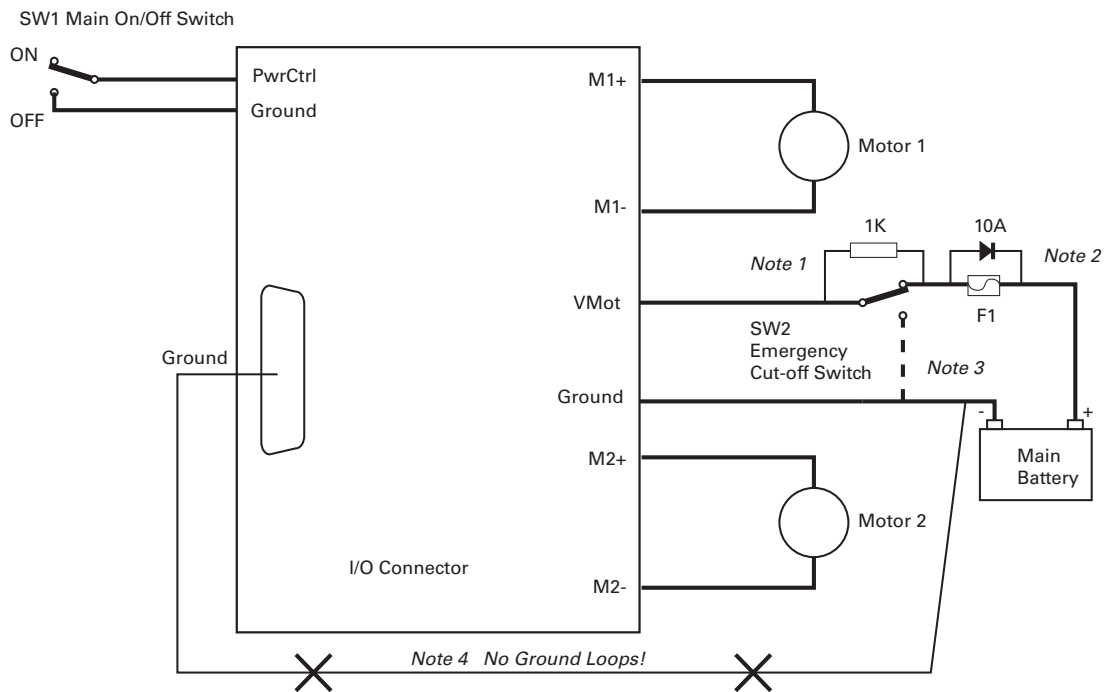

FIGURE 9. Powering the controller. Thick lines identify **MANDATORY** connections

Important Warning

Carefully follow the wiring instructions provided in the Read Me First sheet that comes with the controller, or in the Power Connection section of the User Manual. The information on this datasheet is only a summary.

Mandatory Connections

It is imperative that the controller is connected as shown in the above diagram in order to ensure a safe and trouble-free operation. All connections shown as thick black lines are mandatory. The controller must be powered On/Off using switch SW1 on the Power Control Header.

The battery must be connected in permanence to the controller's VMot power via an input emergency switch SW2 as additional safety measure.

Precautions and Optional Connections

Note1: Use precharge 1K Resistor to prevent switch arcing.

Note2: Insert a high-current diode to ensure a return path to the battery during regeneration in case the fuse is blown.

Note3: Optionally ground the VBat wires when the controller is Off if there is any concern that the motors could be made to spin and generate voltage in excess of 35V.

Note4: Beware not to create a path from the ground pins on the I/O connector and the battery's minus terminal.

Sensor and Commands Connection

Connection to RC Radio, Microcomputer, Joystick and other low current sensors and actuators is done via the 15 connector located in front of the board. The functions of many pins vary depending on user configuration. Pin assignment is found in the table below.

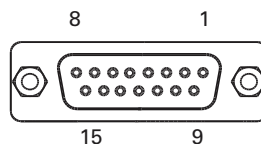

FIGURE 10. Connector pin locations

TABLE 4.

Connector Pin	Power	Dout	Com	RC	Ana	Dinput	Enc	Default Config
1		DOUT1						Unused
9		DOUT2						Unused
2			TxOut					RS232Tx
10				RC5	ANA1	DIN5	ENC2A	AnaCmd1
3			RxIn					RS232Rx
11				RC4	ANA4	DIN4		AnaCmd2
4				RC1		DIN1	ENC1A	RCRadio1
12				RC3	ANA3	DIN3		Unused
5	GND							
13	GND							

TABLE 4.

Connector Pin	Power	Dout	Com	RC	Ana	Dinput	Enc	Default Config
6			TTL TxD / SCLI					TTL Serial TxD
14	5VOut							
7			TTL RxD / SDAI					TTL RxD
15						DIN6	ENC2B	Unused
8				RC2	ANA2	DIN2	ENC1B	RCRadio2

Default I/O Configuration

The controller can be configured so that practically any Digital, Analog and RC pin can be used for any purpose. The controller's factory default configuration provides an assignment that is suitable for most applications. The figure below shows how to wire the controller to two analog potentiometers, an RC radio, and the RS232 port. It also shows how to connect the two outputs to motor brake solenoids. You may omit any connection that is not required in your application. The controller automatically arbitrates the command priorities depending on the presence of a valid command signal in the following order: 1-RS232, 2-RC Pulse, 3-Analog. If needed, use the Robo-run+ PC Utility to change the pin assignments and the command priority order.

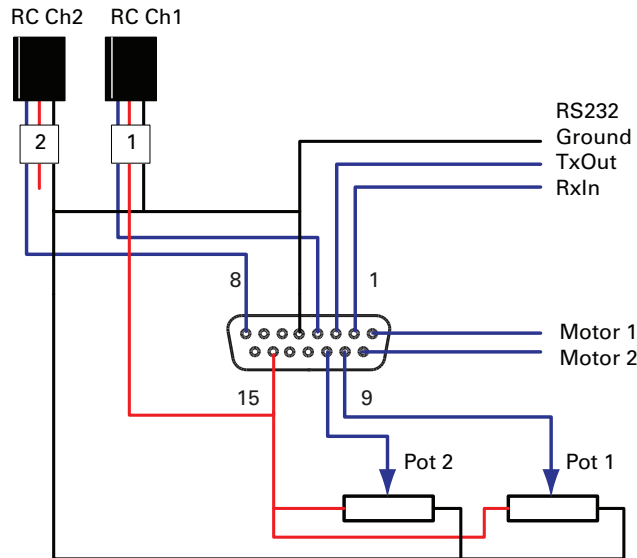

FIGURE 11. Factory default pins assignment

Status LED Flashing Patterns

After the controller is powered on, the Power LED will turn on, indicating that the controller is On. The Status LED will be flashing at a 2 seconds interval. The flashing pattern provides operating or exception status information.



FIGURE 12. Normal Operation Flashing Patterns

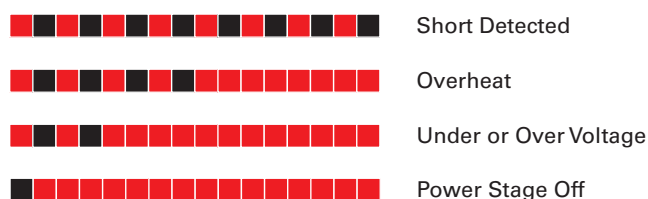

FIGURE 13. Exception or Fault Flashing Patterns

Additional status information may be obtained by monitoring the controller with the PC utility.

Electrical Specifications

Absolute Maximum Values

The values in the table below should never be exceeded, Permanent damage to the controller may result.

TABLE 5.

Parameter	Measure point	Models	Min	Typ	Max	Units
Battery Leads Voltage	Ground to VBat	SDC2130	10		40	Volts
		SDC2150	10		55	Volts
Reverse Voltage on Battery Leads	Ground to VBat	All	-1			Volts
Motor Leads Voltage	Ground to M1+, M1-, M2+, M2-	SDC2130			35	Volts
		SDC2150			55	Volts
Digital Output Voltage	Ground to Output pins	All			30	Volts
Analog and Digital Inputs Voltage	Ground to any signal pin on 25 & 9-pin connectors	All			15	Volts
RS232 I/O pins Voltage	External voltage applied to Rx/Tx pins	All			15	Volts
Board Temperature	Board		-40		85	oC
Humidity	Board				100 (2)	%
Note 1: Maximum regeneration voltage in normal operation. Never inject a DC voltage from a battery or other fixed source						
Note 2: Non-condensing						

Power Stage Electrical Specifications (at 25oC ambient)

TABLE 6.

Parameter	Measure point	Models	Min	Typ	Max	Units
Battery Leads Voltage	Ground to VBat	SDC2130	10 (1)		35	Volts
		SDC2150	10 (1)		55	Volts
Motor Leads Voltage	Ground to M1+, M1-, M2+, M2-	SDC2130	0 (1)		35(2)	Volts
		SDC2150	0 (1)		55(2)	Volts
Over Voltage protection range	Ground to VBat	SDC2130	5	30 (4)	35	Volts
		SDC2150	5	50 (4)	55	Volts
Under Voltage protection range	Ground to VBat	SDC2130	0	5 (4)	35	Volts
		SDC2150	0	5 (4)	55	Volts
Idle Current Consumption	VBat or Pwr Ctrl wires	All	50	75 (5)	100	mA
ON Resistance (Excluding wire resistance)	VBat to M+, plus M- to Ground at 100% power. Per channel	All		20		mOhm
Max Current per channel for 30s	Ch1 or Ch2 Motor current	All			20 (6)	Amps
Continuous Max Current per channel	Ch1 or Ch2 Motor current	All			15 (6)(7)	Amps
Current Limit range	Ch1 or Ch2 Motor current	All	1	15(8)	20	Amps
Stall Detection Amps range	Ch1 or Ch2 Motor current	All	1	15(8)	20	Amps
Stall Detection timeout range	Ch1 or Ch2 Motor current	All	1	500 (9)	65000	milliseconds
Motor Acceleration/Deceleration range	Ch1 or Ch2	All	100	500 (10)	65000	milliseconds

Note 1: Negative voltage will cause a large surge current. Protection fuse needed if battery polarity inversion is possible

Note 2: Maximum regeneration voltage in normal operation. Never inject a DC voltage from a battery or other fixed source

Note 3: Minimum voltage must be present on VBat or Power Control wire

Note 4: Factory default value. Adjustable in 0.1V increments

Note 5: Current consumption is lower when higher voltage is applied to the controller's VBat or PwrCtrl wires

Note 6: When single channel jumper is installed, current is doubled. Current must be balanced between channel to obtain max current.

Note 7: Estimate. Limited by heatsink temperature. Current may be higher with better cooling

Note 8: Factory default value. Adjustable in 0.1A increments

Note 9: Factory default value. Time in ms that Stall current must be exceeded for detection

Note 10: Factory default value. Time in ms for power to go from 0 to 100%

Important Warning:

Beware that regenerative braking can create high voltage at the controller's power inputs. Use the controller only with batteries. See user manual for special precautions when using a power supply.

Command, I/O and Sensor Signals Specifications

TABLE 7.

Parameter	Measure point	Min	Typ	Max	Units
Main 5V Output Voltage	Ground to 5V pins on	4,6	4,75	4,9	Volts
5V Output Current	5V pins on RJ45 and DSub15			100	mA
Digital Output Voltage	Ground to Output pins			30	Volts
Digital Output Current	Output pins, sink current			1	Amps
Output On resistance	Output pin to ground		0,75	1,5	Ohm
Output Short circuit threshold	Output pin	1,05	1,4	1,75	Amps
Input Impedances	AIN/DIN Input to Ground		53		kOhm
Digital Input 0 Level	Ground to Input pins	-1		1	Volts
Digital Input 1 Level	Ground to Input pins	3		15	Volts
Analog Input Range	Ground to Input pins	0		5,1	Volts
Analog Input Precision	Ground to Input pins		0,5		%
Analog Input Resolution	Ground to Input pins		1		mV
Pulse durations	Pulse inputs	20000		10	us
Pulse repeat rate	Pulse inputs	50		250	Hz
Pulse Capture Resolution	Pulse inputs		1		us
Frequency Capture	Pulse inputs	100		10000	Hz
Encoder count	Internal	-2.147		2,15	10 [^] 9 Counts
Encoder frequency	Encoder input pins			30000	Counts/s

Operating & Timing Specifications

TABLE 8.

Parameter	Measure Point	Min	Typ	Max	Units
Command Latency	Command to output change	1	0,5	1	ms
PWM Frequency	Ch1, Ch2 outputs	10	18 (1)	32	kHz
Closed Loop update rate	Internal		1000		Hz
USB Rate	USB pins			12	MBits/s
RS232 baud rate	Rx & Tx pins		115200 (2)		Bits/s
RS232 Watchdog timeout	Rx pin	1 (3)		65000	ms
Note 1: May be adjusted with configuration program					
Note 2: 115200, 8-bit, no parity, 1 stop bit, no flow control					
Note 3: May be disabled with value 0					

Scripting

TABLE 9.

Parameter	Measure Point	Min	Typ	Max	Units
Scripting Flash Memory	Internal		8192		Bytes
Max Basic Language programs	Internal	1000		1500	Lines
Integer Variables	Internal		1024		Words (1)
Boolean Variables	Internal		1024		Symbols
Execution Speed	Internal	50 000	100 000		Lines/s
Note 1: 32-bit words					

Thermal Specifications

TABLE 10.

Parameter	Measure Point	Model	Min	Typ	Max	Units
Board Temperature	PCB	All	-40		85 (1)	oC
Thermal Protection range	PCB	All	70		80 (2)	oC
Thermal resistance	Power MOSFETs to heats sink	All			2	oC/W
Note 1: Thermal protection will protect the controller power						
Note 2: Max allowed power out starts lowering at minimum of range, down to 0 at max of range						

The SDC2130/SDC1260 uses a conduction plate at the bottom of the board for heat extraction. For best results, attach firmly with thermal compound paste against a metallic chassis so that heat transfers to the conduction plate to the chassis. If no metallic surface is available, mount the controller on spacers so that forced or natural air flow can go over the plate surface to remove heat.

Mechanical Specifications

TABLE 11.

Parameter	Measure Point	Min	Typ	Max	Units
Weight	Board		100 (3.5)		g (oz.)
Power Wire Gauge	Terminal strip			12	AWG

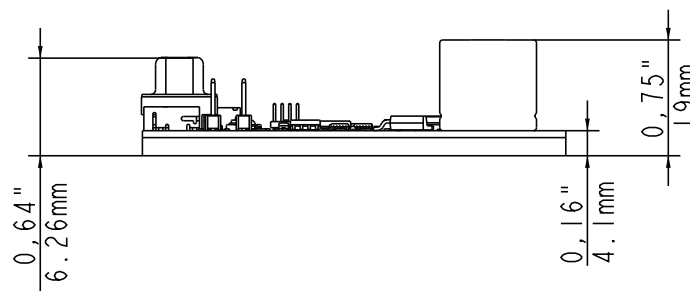

FIGURE 14. SDC2130/SDC2160 front view and dimensions

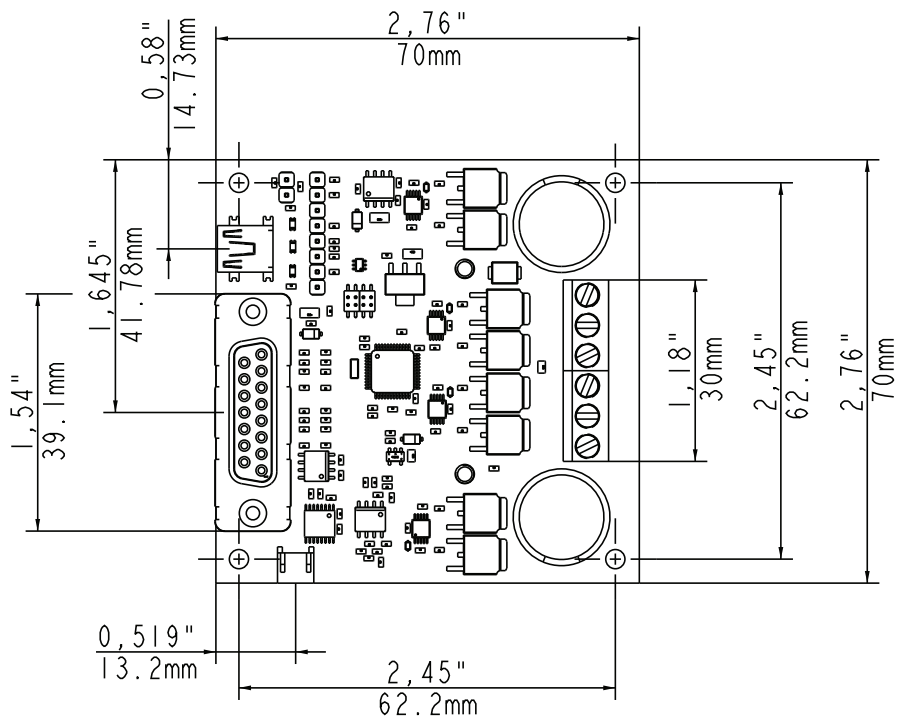

FIGURE 15. SDC2130/SDC2160 top view and dimensions