

# Trimmer Potentiometers



## Angle Sensing Potentiometer SMD Dust-proof Type 12mm Size PVS1 Series

### ■ Features

1. Dust-proof construction protects the internal from dust, which maintains stable characteristics.
2. Compliant to high peak temperature reflow soldering.
3. Excellent resistance materials and high reliability wiper achieves 1M cycles.
4. D formatin thru-hole rotor enables to select any kind of gear shape.
5. Leaded terminal type is available.
6. Ultra-thin size. (2.1mm height)
7. Au plated terminals without Lead.

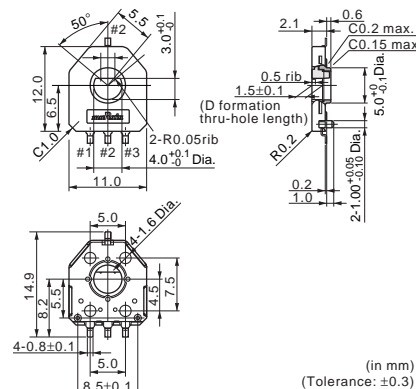

### ■ Applications

1. Animal robot
2. Switch for automotive
3. Motor drive unit
4. Radio control equipment
5. Electric motor-driven bicycle

Part Number	Total Resistance Value (k ohm)	Linearity (%)	Effective Rotational Angle	TCR	Rotational Life
PVS1A103A01	10 ±30%	±2	333.3° (Ref.)	±500ppm/°C	1M cycles

### ■ Construction

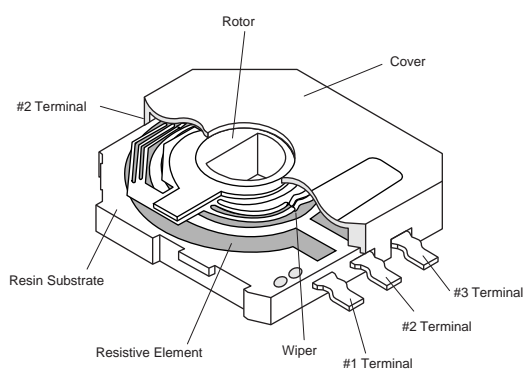

### ■ Standard Land Pattern

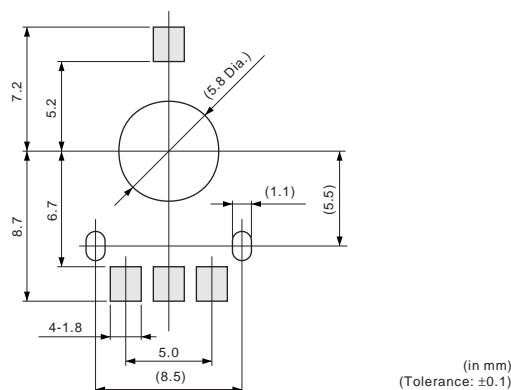

Continued on the following page.

☐ Continued from the preceding page.

**■ Characteristics**

Temperature Cycle (Thermal Shock)	ΔTR	±20%
	Linearity	±3%
Humidity	ΔTR	±20%
	Linearity	±3%
Vibration	ΔTR	±10%
	Linearity	±3%
Shock (20G)	ΔTR	±10%
	Linearity	±3%
Humidity Load Life	ΔTR	±20%
	Linearity	±3%
High Temperature Exposure	ΔTR	+5/-30%
	Linearity	±3%
Low Temperature Exposure	ΔTR	±20%
	Linearity	±3%
Rotational Life (1M cycles)	ΔTR	±20%
	Linearity	±3%

ΔTR: Total Resistance Change

## PVS1 Series Notice

### ■ Notice (Operating and Storage Conditions)

1. Store that the temperature is -10 to +40deg. C and the relative humidity is 30-85%RH.
2. Do not store in or near corrosive gases.
3. Use within six months after delivery.
4. Open the package just before using.
5. Do not store under direct sunlight.
6. Do not use the rotary position sensor under the following environmental conditions. If you use the rotary position sensor in an environment other than these listed below, please consult with Murata factory representative prior to using.

- (1) Corrosive gasses atmosphere.  
(Ex. Chlorine gas, Hydrogen sulfide gas, Ammonia gas, Sulfuric acid gas, Nitric oxide gas, etc.)
- (2) In liquid.  
(Ex. Water, Oil, Medical liquid, Organic solvent, etc.)
- (3) Dusty/dirty atmosphere.
- (4) Direct sunlight.
- (5) Static voltage nor electric/magnetic fields.
- (6) Direct sea breeze.
- (7) Other variations of the above.

### ■ Notice (Soldering and Mounting)

#### 1. Soldering

- (1) PVS1 series can be soldered by reflow soldering method and soldering iron. Do not use flow soldering method (dipping).
- (2) The dimension of land pattern should be used Murata's standard land pattern at reflow soldering. Excessive land area may cause displacement due to effect of the surface tension of the solder. Insufficient land area may cause insufficient soldering strength on PCB.
- (3) Standard soldering condition
  - (a) Reflow soldering : Refer to the standard temperature profile.
  - (b) Soldering iron:
    - >Temperature of tip 360deg. C max.
    - >Soldering time 3sec. max./1 terminal
    - >Diameter 3mm max.
    - >Wattage of iron 30W max.

Before using other soldering conditions than those listed above, please consult with Murata factory representative prior to using. If the soldering conditions are not suitable, e.g., excessive time and/or excessive temperature, the rotary position sensor may deviate from the specified characteristics.

- (4) The amount of solder is critical. Insufficient amounts of solder can lead to insufficient soldering strength on PCB. Excessive amounts of solder may cause the bridging between the terminals.
  - (5) The soldering iron should not come in contact with the cover of the rotary position sensor. If such contact does occur, the rotary position sensor may be damaged.
- #### 2. Cleaning
- Can not be cleaned because of open construction.

### ■ Reflow Soldering Standard Profile

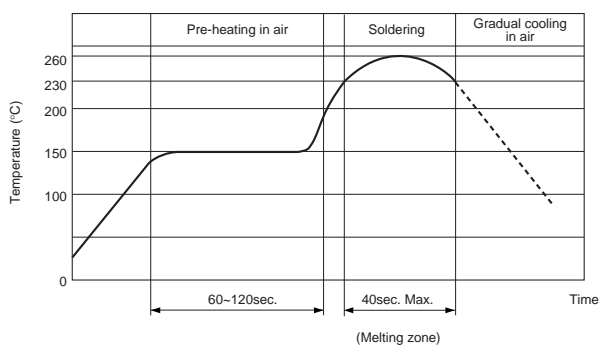

## PVS1 Series Notice

### ■ Notice (Handling)

1. Do not warp and/or bend PCB to prevent rotary position sensor from breakage.
2. In case that load to the product except rotor and/or excessive force except rotational action to the rotor are applied to the product, the change of the electrical characteristics, increase in torque and mechanical damage may occur. Therefore, please pay attention to the fixing method and holding method of the shaft to avoid the foregoing.

### ■ Notice (Other)

1. Please make sure the connecting impedance is not to be less than 1M ohm. The rotary position sensor is designed to connect the output terminal and A/D port of the microprocessor directly. Therefore, connecting impedance presuppose certain M ohm and the contact resistance is set high.
  - (1) Data install should be done plural times and applied the mean value.
  - (2) Data considered as error should be invalid.
  - (3) Data should be re-installed if quare occurs.
2. To minimize the processing error and noise influence which occur in rare cases, when data is installed through the product, please note the following items and program your software.
  3. Before using rotary position sensor, please test after assembly in your particular mass production system.
  4. MURATA cannot guarantee rotary position sensor integrity when used under conditions other than those specified in this document.

## Angle Sensing Potentiometer Specifications and Test Methods

No.	Item	Test Methods															
1	Linearity	<p>Independent linearity shall vary no more than <math>\pm 2\%</math> within <math>\pm 160^\circ</math> to 50% voltage ratio.                      Taper : linear, 100%/333.3° Measured with the circuit as below (Figure-1).</p> <div style="display: flex; justify-content: space-around; align-items: flex-start;"> <div style="text-align: center;"> <p>Output voltage ratio (%)</p> <math display="block">\left( \frac{V(1-2)}{V(1-3)} \times 100 \right)</math> <p>Rotational angle (°)</p> </div> <div style="text-align: center;"> <p>DC5V (#3)    GND (#1)</p> <p>Output (#2)</p> <p>Connection Impedance : 1M ohm min.</p> </div> </div> <p style="text-align: right;">Figure-1</p>															
2	Temperature Coefficient of Resistance	<p>The rotary position sensor shall be subjected to the following each temperature (see Table-1) for 30-45 minutes. Temperature coefficient of resistance shall be applied to the following formula.</p> $TCR = \frac{R_2 - R_1}{R_1 (t_2 - t_1)} \times 10^6 \text{ (ppm/}^\circ\text{C)}$ <p> <math>t_1</math> : Reference temperature in degrees celsius  <math>t_2</math> : Test temperature in degrees celsius  <math>R_1</math> : Resistance at reference temperature in ohm  <math>R_2</math> : Resistance at test temperature in ohm                 </p> <table border="1" style="width: 100%; border-collapse: collapse; text-align: center;"> <thead> <tr> <th>Sequence</th> <th>*1</th> <th>2</th> <th>*3</th> <th>4</th> </tr> </thead> <tbody> <tr> <td>Temperature (°C)</td> <td>+25</td> <td>-40</td> <td>+25</td> <td>+85</td> </tr> </tbody> </table> <p>Note) * : Reference temperature</p> <p style="text-align: center;">Table-1 Test temperatures</p>	Sequence	*1	2	*3	4	Temperature (°C)	+25	-40	+25	+85					
Sequence	*1	2	*3	4													
Temperature (°C)	+25	-40	+25	+85													
3	Temperature Cycle (Thermal Shock)	<p>The rotary position sensor shall be subjected to Table-2 temperature for 5 cycles. Then, the rotary position sensor shall be kept in the dry box for 24 +8/-0 hrs.</p> <table border="1" style="width: 100%; border-collapse: collapse; text-align: center;"> <thead> <tr> <th>Sequence</th> <th>1</th> <th>2</th> <th>3</th> <th>4</th> </tr> </thead> <tbody> <tr> <td>Temperature (°C)</td> <td>-40±3</td> <td>+25±2</td> <td>+85±3</td> <td>+25±2</td> </tr> <tr> <td>Time (min.)</td> <td>30</td> <td>5 max.</td> <td>30</td> <td>5 max.</td> </tr> </tbody> </table> <p style="text-align: center;">Table-2 One cycle of temperature cycle</p>	Sequence	1	2	3	4	Temperature (°C)	-40±3	+25±2	+85±3	+25±2	Time (min.)	30	5 max.	30	5 max.
Sequence	1	2	3	4													
Temperature (°C)	-40±3	+25±2	+85±3	+25±2													
Time (min.)	30	5 max.	30	5 max.													
4	Humidity	<p>The rotary position sensor shall be stored in a chamber at temperature of <math>+60 \pm 2^\circ\text{C}</math> and relative Humidity of 90-95% for 250±8 hrs. After removing from the chamber, the rotary position sensor shall be kept in the dry box for 24 +8/-0 hours.</p>															
5	Vibration	<p>The rotary position sensor shall be tested under the condition of the amplitude of 1.5mm, the frequency range from 10 to 55Hz (shall be traversed in approximately one minute) and 2 hours in each of 3 mutually perpendicular directions. (Total 6 hours) Then, the rotary position sensor shall be kept in the dry box for 1-2 hrs.</p>															
6	Shock	<p>The rotary position sensor shall be tested under the condition of the peak acceleration 20G max. in half-sine wave and 5 shocks in each of 3 mutually perpendicular directions. (Total 15 shocks) Then, the rotary position sensor shall be kept in the dry box for 1-2 hrs.</p>															
7	Humidity Load Life	<p>Full rated continuous working voltage not exceeded 5Vdc shall be applied intermittently between the terminal #1 and the terminal #3 of the rotary position sensor, 1.5 hours on and 0.5 hours off, for 96±4 hours in total in a chamber at the temperature of <math>+40 \pm 2^\circ\text{C}</math> and the relative humidity of 90-95%. After removing from the chamber, the rotary position sensor shall be kept in the dry box for 24 +8/-0 hours.</p>															
8	High Temp. Exposure	<p>The rotary position sensor shall be stored in a chamber at the temperature of <math>+85 \pm 3^\circ\text{C}</math> without loading for 250±8 hours. After removing from the chamber, the rotary position sensor shall be kept in the dry box for 24 +8/-0 hours.</p>															
9	Low Temp. Exposure	<p>The rotary position sensor shall be stored in a chamber at the temperature of <math>-40 \pm 3^\circ\text{C}</math> without loading for 168±4 hours. After removing from the chamber, the rotary position sensor shall be kept in the dry box for 24 +8/-0 hours.</p>															
10	Rotational Life	<p>The adjustment rotor shall be continuously rotated within <math>\pm 160^\circ</math> of effective electrical rotational angle, at the rate of one cycle for 6 seconds for 1 Million cycles under the condition of <math>+25 \pm 2^\circ\text{C}</math> of temperature without loading.</p>															

## Packaging

### ■ Minimum Quantity

Part Number	Minimum Quantity (pcs.)				
	ø180mm reel	ø330mm reel	Ammo Pack	Magazine	Bulk
PVZ2A	3000	12000	—	—	1000
PVZ2K	3000	—	—	—	1000
PVZ3A	2000	8000	—	—	1000
PVZ3K/R	1500	—	—	—	1000
PVZ3T	—	—	—	—	2000
PVS3	2500	8000	—	—	500
PVA3	2000	8000	—	—	500
PVG3A/G	1000	—	—	—	500
PVG3K	500	—	—	—	—
PVM4	500	3000	—	—	500
PVF2A	500	—	—	—	100
PVG5A	250	—	—	—	50
PVG5H	500	—	—	—	50
PV01W	—	—	—	70	—
PV01P/X	—	—	—	60	—
PVC6A/D/G/H/E	—	—	—	50	50
PVC6M/Q	—	—	1000	50	50
PV34	—	—	—	—	100
PV32	—	—	—	—	100
PV23/12	—	—	—	—	50
PV22	—	—	—	—	30
PV36W	—	—	1000	50	50
PV36Y	—	—	—	50	50
PV36X	—	—	1000	40	50
PV36Z/P	—	—	—	40	50
PV37Y/Z	—	—	1000	—	50
PV37W/X/P	—	—	—	—	50
PVS1	—	1000	—	—	50

### ■ Dimensions of Reel

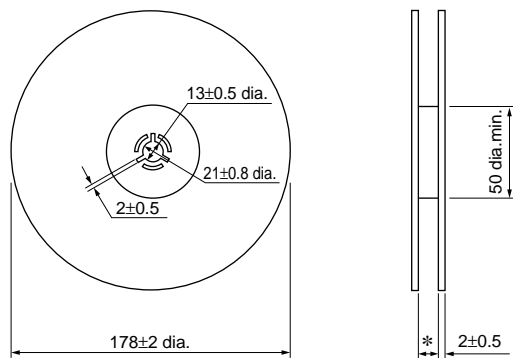

\* 10±1.5 ( 8mm Width) — PVZ2A, PVZ3A, PVS3, PVA3, PVF2  
 14±1.5 (12mm Width) — PVG5H, PVG3, PVZ2K, PVZ3K, PVZ3R, PVM4  
 18±1.5 (16mm Width) — PVG5A

(in mm)

Continued on the following page.

## Packaging

Continued from the preceding page.

### ■ Dimensions of Reel

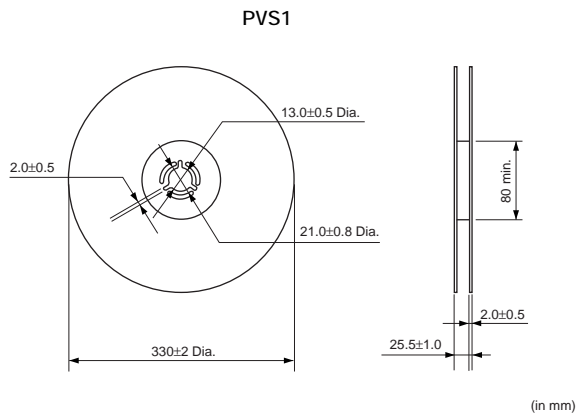

### ■ Dimensions of Plastic Tape

#### PVZ2 / PVZ3 / PVA3 / PVS3 / PVF2

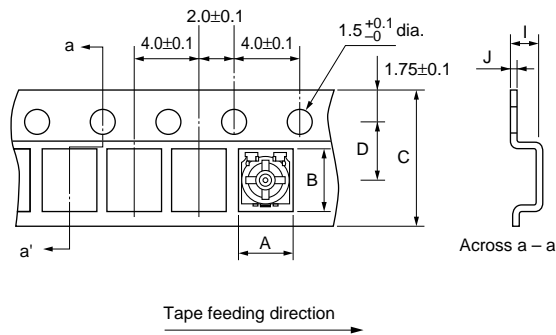

Part Number	A	B	C	D	I	J
<b>PVZ2A</b>	2.4±0.1	3.1±0.1	8.0±0.2	3.5±0.1	1.1±0.1	0.2±0.1
<b>PVZ2K</b>		5.7±0.1	12.0±0.1	5.5±0.1		0.3±0.1
<b>PVZ3A/PVA3</b>	3.3±0.2	3.8±0.2	8.0±0.2	3.5±0.1	1.95±0.1	0.2±0.1
<b>PVZ3K</b>		5.8±0.2	12.0±0.2	5.5±0.1	2.3±0.1	0.3±0.1
<b>PVZ3R</b>		6.5±0.2			2.1±0.1	
<b>PVS3</b>		4.1±0.2	8.0±0.2	3.5±0.1	1.6±0.1	0.2±0.1
<b>PVF2</b>	2.3±0.2	2.3±0.2			2.3±0.1	0.3±0.1

• The side containing terminals #1 and #3 faces the plastic tape pilot holes.

(in mm)

Continued on the following page. ↗

## Packaging

Continued from the preceding page.

### ■ Dimensions of Plastic Tape

#### PVG3A / PVG3G / PVM4 / PVG5H

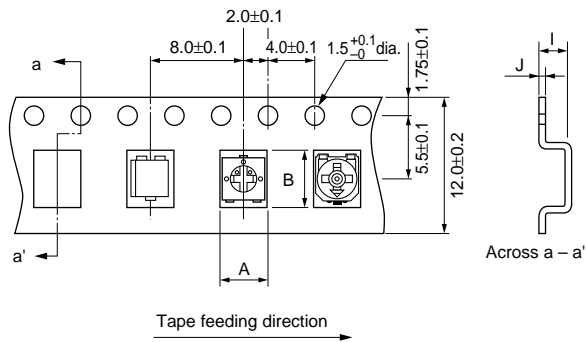

Part Number	A	B	I	J
<b>PVG3A</b>	4.0±0.1	4.0±0.1	2.1±0.1	0.3±0.1
<b>PVG3G</b>		4.9±0.1		
<b>PVM4</b>	4.5±0.2	5.5±0.2	2.15±0.1	0.3±0.1
<b>PVG5H</b>	5.4±0.2	5.8±0.2	4.0±0.1	0.4±0.1

• The side containing terminals #1 and #3 faces the plastic tape pilot holes.  
(except PVG3)

(in mm)

#### PVG5A

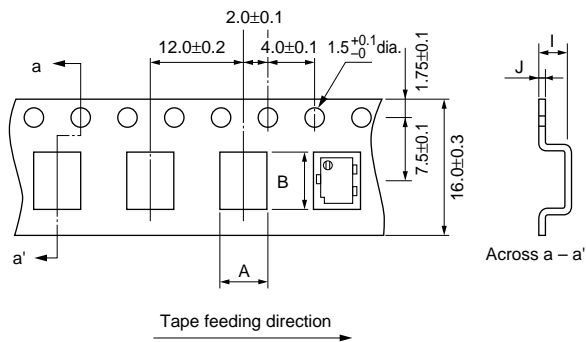

Part Number	A	B	I	J
<b>PVG5A</b>	4.3±0.2	5.4±0.2	5.4±0.1	0.4±0.1

(in mm)

Continued on the following page. ↗



# Packaging

Continued from the preceding page.

## ■ Dimensions of Plastic Tape

PVG3K

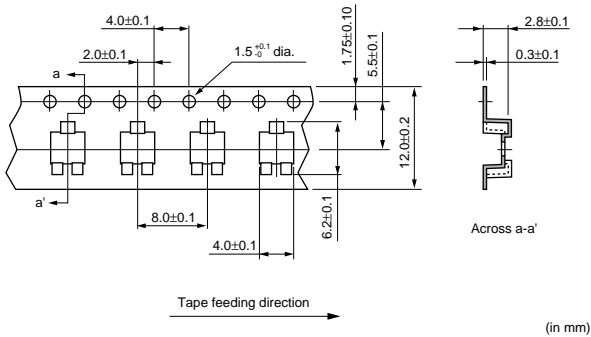

(in mm)

PVS1

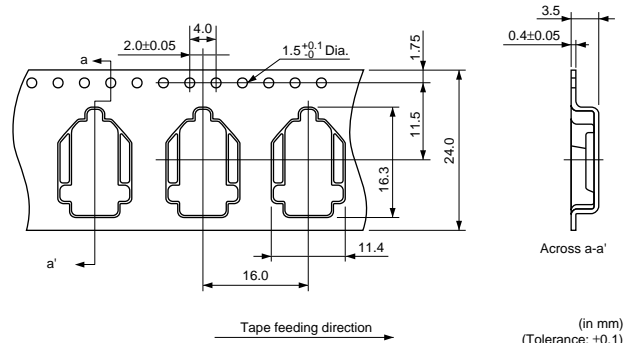

(in mm)  
(Tolerance: ±0.1)

## ■ Dimensions of Radial Taping

PVC6M

0.55W×3.2L×1.3D

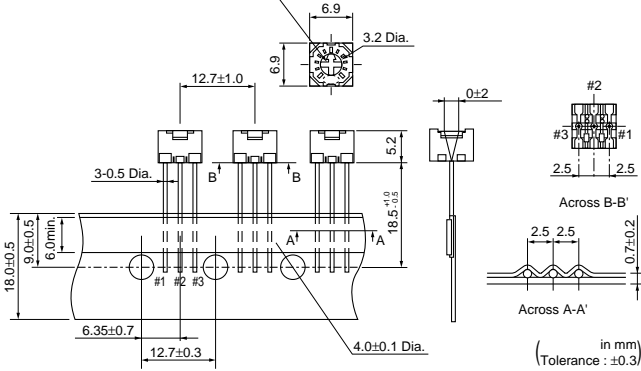

(in mm)  
(Tolerance: ±0.3)

PVC6Q

0.55W×3.2L×1.3D

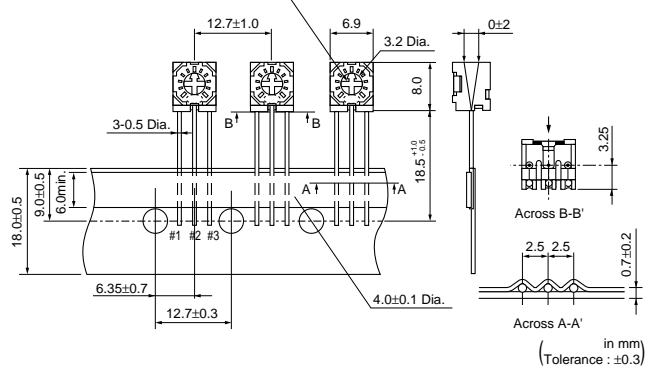

(in mm)  
(Tolerance: ±0.3)

PV37Y

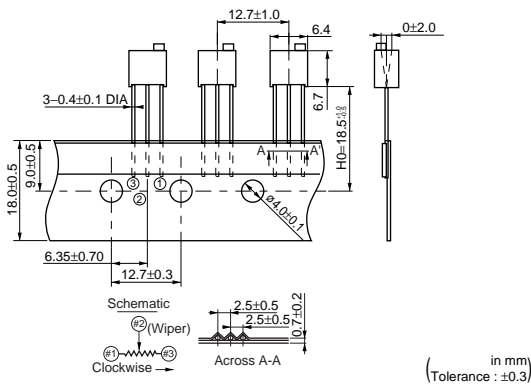

(in mm)  
(Tolerance: ±0.3)

PV37Z

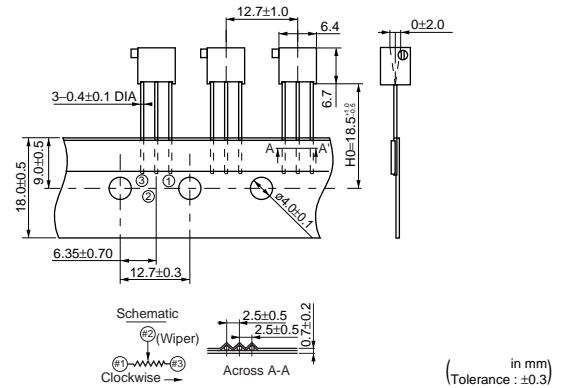

(in mm)  
(Tolerance: ±0.3)

Continued on the following page. ↗