



WiRobot SDK Application Programming Interface (API) Reference Manual - (For MS Windows)

Dr Robot[®]

Version: 1.0.8
Feb. 2004

Table of Contents

I.	Convention	2
II.	WiRobot SDK Overview	3
III.	WiRobot SDK API Reference for PMS5005.....	5
III.1.	Sensor Peripherals	5
III.1.1.	Batch Sensor Data Updating API.....	5
III.1.2.	Range and Distance Sensors.....	8
III.1.3.	Human Sensors.....	9
III.1.4.	Tilt and Acceleration Sensor.....	10
III.1.5.	Temperature Sensors.....	11
III.1.6.	Infrared Remote Control Handling	12
III.1.7.	Battery Voltage Monitors.....	13
III.1.8.	Potentiometer Position Sensors	14
III.1.9.	Motor Current Sensors.....	15
III.1.10.	Encoder.....	16
III.1.11.	Custom Analog and Digital Inputs and Outputs	17
III.2.	Motion Control.....	19
III.2.1.	DC Motor Control.....	19
III.2.2.	RC Servo Motor Control	31
III.3.	Multimedia Control.....	33
III.3.1.	LCD Display	33
III.4.	Events.....	34
IV.	WiRobot SDK API Reference for PMB5010.....	35
IV.1.	Multimedia Control.....	35
IV.1.1.	Audio Input and Output.....	35
IV.1.2.	Image Capturing.....	37
IV.1.3.	LCD Display	38
IV.2.	Events.....	38
V.	WiRobot DRK6000/8000 Specific APIs.....	39
V.1.	Low Level Protection	39

I. Convention

Data Type

int:	16 bit signed interger
UWord16:	16 bit unsigned interger
short:	16 bit signed interger

Syntax

Syntax under each API reference is based on the C/C++ calling convention. Corresponding Visual Basic calling convention can be found in relevant VB reference book, or from the WiRobot VB code examples.

II. WiRobot SDK Overview

WiRobot Software Development Kit (SDK) is a part of the WiRobot development system. Being a PC-based software framework for robotic system development, the SDK contains the facilities for memory management, system communication and user interface, and the utilities for audio, video input/output, sensor data acquisition and motion control. Please refer to the WiRobot PMS5005, PMB5010, or DRK6000/8000 User Manuals for the detailed information on the SDK architecture, organization and system programming.

Under the WiRobot system architecture, all the controllers are connected in a chain. Programs developed using WiRobot SDK runs on the Host as the central controller of each chain. All the embedded controllers have at least two SCI ports for the system communications: upper-reach port and lower-reach port, with the direction respect to the central controller. The WiRobot system controller-level connection architecture is shown as Figure II.1.

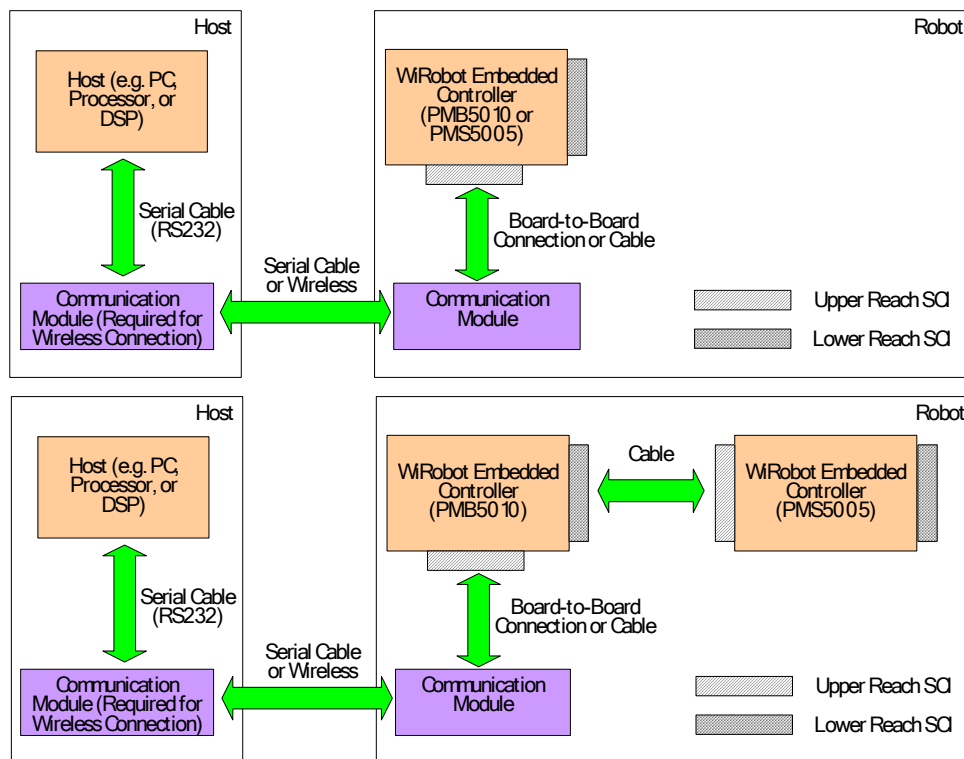

Figure II.1 WiRobot System Architecture

The APIs described in this manual are the interface between the application-level software and the WiRobot hardware system. Programs developed using WiRobot SDK runs on the PC sending and receiving data to and from the WiRobot hardware via wire or wireless connection. The firmware on the embedded controllers take care of all the low level operations of the system functional modules, such as data acquisition, fast-loop low level motion control, image and audio capture and compression, audio playback and wireless communication. They are transparent to the high level software system running on the central PC controller. All the system software development can be carried on solely under user-friendly PC system. WiRobot SDK for Windows is available for MS Visual C++ and MS Visual Basic environment.

API exists as a MS ActiveX component, called "WiRobot SDK ActiveX Module". User program uses this component in VB or VC++ program to communicate with the WiRobot PMS5005 or/and PMB5010 controllers. Data in between WiRobot hardware and the "WiRobot SDK ActiveX Module" is managed and transferred by the supplied WiRobot Gateway Program (WiRobotGateway.exe) with the shared memory as shown in Figure II.2.

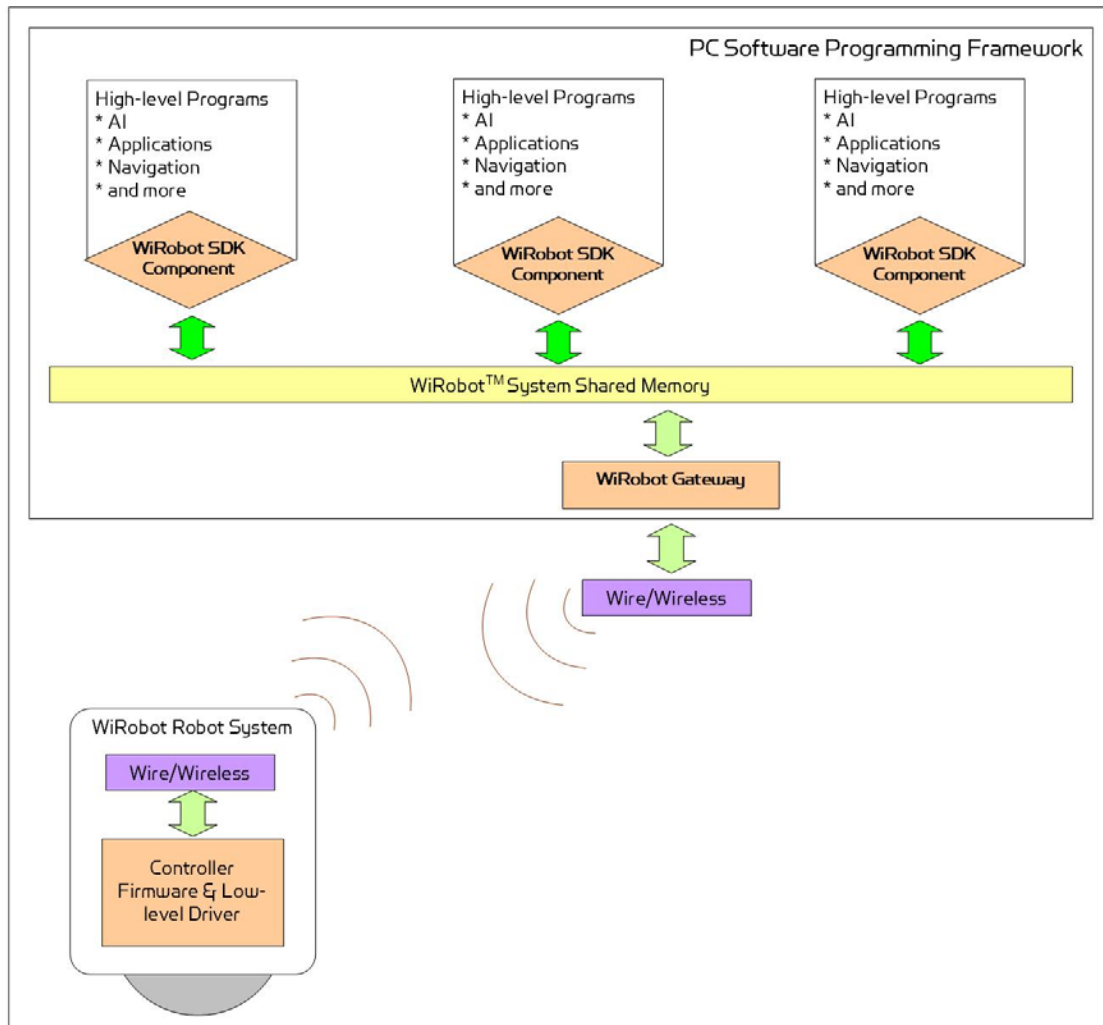

Figure II.2 WiRobot Software Architecture

III. WiRobot SDK API Reference for PMS5005

WiRobot SDK APIs for PMS5005 are grouped under the categories of Sensor Peripherals, Motion Control, Multimedia Control and Events.

III.1. Sensor Peripherals

This section contains the APIs for the operations of different sensor peripherals.

III.1.1. Batch Sensor Data Updating API

Standard Sensors: Sonar, human, infrared range, tilt/acceleration, temperature, battery voltage and infrared remote control receiver

Motor Sensors: Potentiometers, current feedback sensors and encoders.

Custom Sensors: Custom expansion A/D inputs and digital inputs.

- 1 **void SystemMotorSensorRequest(int PacketNumber);**
- 2 **void SystemStandardSensorRequest(int PacketNumber);**
- 3 **void SystemCustomSensorRequest(int PacketNumber);**
- 4 **void SystemAllSensorRequest(int PacketNumber);**

Description:

SystemMotorSensorRequest sends a request command to the WiRobot Sensing and Motion Controller (PMS5005) in order to get the sensor data related to motor control.

SystemStandardSensorRequest sends a request command to the WiRobot Sensing and Motion Controller (PMS5005) in order to get all the WiRobot standard sensor data.

SystemCustomSensorRequest sends a request command to the WiRobot Sensing and Motion Controller (PMS5005) in order to get all custom-sensor data,

SystemAllSensorRequest sends a request command to the WiRobot Sensing and Motion Controller (PMS5005) in order to get all the sensor data.

Syntax: SystemMotorSensorRequest (PacketNumber); // motor related sensors
 SystemStandardSensorRequest (PacketNumber); // standard sensors
 SystemCustomSensorRequest (PacketNumber); // custom sensors
 SystemAllSensorRequest (PacketNumber); // all the sensors

Parameter: short PacketNumber;

The meanings of PacketNumber as follows:

Parameter	Action Requested
PacketNumber = 0	Stop sending the sensor data packets
PacketNumber = -1	Send sensor data packet continuously until being asked to stop
PacketNumber > 0	Send n = PacketNumber packet(s) of sensor data and then stop sending

Return value: void

Remarks:

1. The default update rate is 20Hz. User can set up the data refresh rate according to real system requirements.
2. System is default to continuously sending all data when bootup.

See Also: **SetSysMotorSensorPeriod**, **SetSysStandardSensorPeriod**, **SetSysCustomSensorPeriod**, **SetSysAllSensorPeriod**.

```
5 void EnableMotorSensorSending ();
6 void EnableStandardSensorSending ();
7 void EnableCustomSensorSending ();
8 void EnableAllSensorSending ();
```

Description:

EnableMotorSensorSending enables batch updating motor-related sensor packets.

EnableStandardSensorSending enables batch updating standard sensor packets.

EnableCustomSensorSending enables batch updating custom sensor packets.

EnableAllSensorSending enables batch updating all the sensor packets.

```
Syntax:    EnableMotorSensorSending();           // motor related sensors
           EnableStandardSensorSending ();       // standard sensors
           EnableCustomSensorSending ();        // custom sensors
           EnableAllSensorSending ();          // all the sensors
```

Parameter: void

Return value: void

Remarks:

1. The latest request setting of the packet number and the update rate are used.
2. By default, "all sensor data sending" is enabled.
3. Please refer to the remarks under **SystemMotorSensorRequest**, **SystemStandardSensorRequest**, **SystemCustomSensorRequest**, **SystemAllSensorRequest**

```
9 void DisableMotorSensorSending ();
10 void DisableStandardSensorSending ();
11 void DisableCustomSensorSending ();
12 void DisableAllSensorSending ();
```

Description:

DisableMotorSensorSending disables batch updating motor-related sensor packets.

DisableStandardSensorSending disables batch updating standard sensor packets.

DisableCustomSensorSending disables batch updating custom sensor packets.

DisableAllSensorSending disables batch updating all the sensor packets.

```
Syntax:      DisableMotorSensorSending();           // motor related sensors
              DisableStandardSensorSending ();      // standard sensors
              DisableCustomSensorSending ();       // custom sensors
              DisableAllSensorSending ();          // all the sensors
```

Parameter: void

Return value: void

See Also: **SystemMotorSensorRequest**, **SystemStandardSensorRequest**,
SystemCustomSensorRequest, **SystemAllSensorRequest**.

- 13 void SetSysMotorSensorPeriod(short PeriodTime) ;
- 14 void SetSysStandardSensorPeriod(short PeriodTime);
- 15 void SetSysCustomSensorPeriod(short PeriodTime) ;
- 16 void SetSysAllSensorPeriod(short PeriodTime) ;

Description:

SetSysMotorSensorPeriod sets refresh rate of batch updating motor-related sensor packets.

SetSysStandardSensorPeriod sets refresh rate of batch updating standard sensor packets.

SetSysCustomSensorPeriod sets refresh rate of batch updating custom sensor packets.

SetSysAllSensorPeriod sets refresh rate of batch updating all the sensor packets.

```
Syntax:      SetSysMotorSensorPeriod ();           // motor related sensors
              SetSysStandardSensorPeriod ();      // standard sensors
              SetSysCustomSensorPeriod ();       // custom sensors
              SetSysAllSensorPeriod ();          // all the sensors
```

Parameter: short PeriodTime; /* Update period (in ms) for batch sensing
packets to PC central controller */

Return value: void

Remarks:

The default PeriodTime = 50 (ms), i.e. update rate is 20Hz. PeriodTime should be bigger than 50 (ms), i.e. the system data fastest refresh rate is 20Hz.

See Also: **SystemMotorSensorRequest**, **SystemStandardSensorRequest**,
SystemCustomSensorRequest, **SystemAllSensorRequest**.

III.1.2. Range and Distance Sensors

```

17 short GetSensorSonar1 ();
18 short GetSensorSonar2 ();
19 short GetSensorSonar3 ();
20 short GetSensorSonar4 ();
21 short GetSensorSonar5 ();
22 short GetSensorSonar6 ();
23 short GetSensorSonar (short channel);

```

Description:

GetSensorSensorX returns the current distance value between the relevant ultrasonic range sensor module (DUR5200) and the object in front of it. The unit is cm.

Syntax: ival = GetSensorSonar1 (); // Sonar #1
 ival = GetSensorSonar2 (); // Sonar #2
 ival = GetSensorSonar3 (); // Sonar #3
 ival = GetSensorSonar4 (); // Sonar #4
 ival = GetSensorSonar5 (); // Sonar #5
 ival = GetSensorSonar6 (); // Sonar #6
 ival = GetSensorSonar (short channel); // Sonar #1, 2, 3, 4, 5, or 6

Parameter: void
 short channel; // 0, 1, 2, 3, 4, or 5 for Sonar #1, 2, 3, 4, 5, 6

Return value: short ival;

Return data interpretation:

Return Value	Distance to Object
4	0 to 4 cm
4 to 254	4 to 254 cm
255	255 cm or longer

24 short GetSensorIRRange ();

Description:

GetSensorIRRange returns the current distance measurement value between the infrared range sensor and the object in front of it.

Syntax: ival = GetSensorIRRange ();

Parameter: void

Return value: short ival;

Return data interpretation when using Sharp GP2Y0A21YK:

Return Value	Distance to Object
<=585	80 cm or longer
585 to 3446	80 to 8 cm
>=3446	0 to 8 cm

Remarks:

The relationship between the return data and the distance is not linear. Please refer to the sensor's datasheet for distance-voltage curve. The data returned is the raw data of the analog to digital converter. The output voltage of the sensor can be calculated from the following equation:

$$\text{Sensor output voltage} = (\text{ival}) * 3.0 / 4095 \text{ (V)}$$

(e.g. Sharp GP2Y0A21YK

"http://sharp-world.com/products/device/lineup/data/pdf/datasheet/gp2y0a_d_e.pdf")

III.1.3. Human Sensors

25 **short GetSensorHumanAlarm1 ();**

26 **short GetSensorHumanAlarm2 ();**

Description:

GetSensorHumanAlarm returns the current human alarm data from DHM5150 Human Motion Sensor Module. Please refer to the DHM5150 hardware manual for detailed information.

Syntax: ival = GetSensorHumanAlarm1(); //1st human alarm
 ival = GetSensorHumanAlarm2 (); //2nd human alarm

Parameter: void

Return value: short ival;

Return data interpretation:

The return data is the raw value of the analog to digital converter indicating the amplified (x 5 times) output voltage of the sensor device. The data range is between 0 and 4095. When there is no human present, the module output voltage is about 1.5 V and return value is about 2047.

Remarks:

To detect human presence, the application should compare the difference of two samples (to detect the change from "absence" to "presence"), and also compare the sample data to a user defined threshold (to determine whether to report an alarm or not). The threshold determines the sensitivity of sensor. The higher the threshold is the lower the sensitivity will be.

- 27 short GetSensorHumanMotion1 ();
 28 short GetSensorHumanMotion2 ();

Description:

GetSensorHumanMotion returns the current human motion value from DHM5150 Human Motion Sensor Module. Please refer to the DHM5150 hardware manual for detailed information.

```
Syntax:      ival = GetSensorHumanMotion1 ();      // Human direction data #1
              ival = GetSensorHumanMotion2 ();      // Human direction data #2
```

Parameter: void

Return value: short ival;

Return data interpretation:

The return data is the un-amplified raw value of the analog to digital converter indicating the output voltage of the sensor device. The data range is between 0 and 4095.

Remarks:

To detect human motion direction, the application should compare the difference of two samples of each sensor module's output (to detect the change from "absence" to "presence"), and then compare the sample data of the two sensor modules. For a single source of human motion, the different patterns of the two sensor modules manifest the directions of the motion. The relationship can be obtained from the experiments.

III.1.4. Tilt and Acceleration Sensor

- 29 short GetSensorTiltingX ();
 30 short GetSensorTiltingY ();

Description:

GetSensorTiltingX, **GetSensorTiltingY**, return the current tilt angle values in the relevant directions from DTA5102 Tilting and Acceleration Sensor Module.

```
Syntax:      ival = GetSensorTiltingX ();      // X direction
              ival = GetSensorTiltingY ();      // Y direction
```

Parameter: void

Return value: short ival;

Return data interpretation:

Tilting Angle = ArcSin ((ival- ZeroGValue) / abs(90DegreeGValue-ZeroGValue));

Remarks:

Where 90DegreeGValue and ZeroGValue are module-specific values that can be measured by experiment:

1. Place the sensor level, so that the gravity vector is perpendicular to the measured sensor axis
2. Take the measurement and this value would be the ZeroGValue
3. Rotate the sensor so that the gravity vector is parallel with the measured axis
4. Take the measurement and this value would be the 90DegreeGValue
5. Repeat this step for the other direction

Typical value of ZeroGValue is about 2048 and $\text{abs}(90\text{DegreeGValue}-\text{ZeroGValue})$ is about 1250.

III.1.5. Temperature Sensors

31 short GetSensorOverheatAD1 ();

32 short GetSensorOverheatAD2 ();

Description:

GetSensorOverheatADX returns the current air temperature values near the relevant DC motor drive modules (MDM5253), which could be used for monitoring whether the motor drivers are overheating or not. This situation usually occurs if the motor currents are kept high (but still lower than the current limit of the motor driver module) for significant amount of time, which may result from some unfavorable inner or external system conditions and is not recommended for regular system operations.

Syntax: ival = GetSensorOverheatAD1(); //1st overheating sensor
 ival = GetSensorOverheatAD2(); //2nd overheating sensor

Parameter: void

Return value: short ival;

Return data interpretation:

The return data is the raw value of the analog to digital converter indicating the output voltage of the sensor. The data range of the return value is between 0 and 4095. The output voltage of the sensor can be calculated from the following equation:

$$\text{Temperature (}^{\circ}\text{C)} = 100 - (\text{ival} - 980) / 11.6$$

33 short GetSensorTemperature ();

Description:

GetSensorTemperature returns the current temperature value from DAT5280 Ambient Temperature Sensor Module.

Syntax: ival = GetSensorTemperature ();

Parameter: void
Return value: short ival;

Return data interpretation:
Temperature (°C) = (ival - 1256) / 34.8

III.1.6. Infrared Remote Control Handling

```
34 short GetSensorIRCode1();
35 short GetSensorIRCode2();
36 short GetSensorIRCode3();
37 short GetSensorIRCode4();
```

Description:

GetSensorIRCodeX returns the four parts of a two-16-bit-code infrared remote control command captured by the Sensing and Motion Controller (PMS5005) through the Infrared Remote Controller Module (MIR5500).

```
Syntax:          ival = GetSensorIRCode1 ();    // the first code
                  ival = GetSensorIRCode2 ();    // the second code
                  ival = GetSensorIRCode3 ();    // the third code
                  ival = GetSensorIRCode4 ();    // the fourth code
```

Parameter: void
Return value: short ival

Return data interpretation:
The recovered infrared remote control command (4 bytes code) is as follows:

Key Code: [the third byte] [the second byte] [the first byte]
Repeat Code: [the fourth byte]

where the repeat code would be 255 if button is pressed continuously.

```
38 void SetInfraredControlOutput (UWord16 LowWord, UWord16 HighWord);
```

Description:

SetInfraredControlOutput sends two 16-bit words infrared communication output data to the Sensing and Motion Controller (PMS5005). The PMS5005 will then send the data out through the infrared Remote Controller Module (MIR5500). In the case of being used for infrared remote control, the output data serves as the remote control command.

Syntax: SetInfraredControlOutput (LowWord, HighWord);

```
Parameter: void // for GetSensorPotX
           short channel; /* 0, 1, 2, 3, 4, or 5 for Potentiometer #
                           1, 2, 3, 4, 5, 6 */
```

Return value: short ival;

Return data interpretation & Remark:

1. The return data is the raw value of the analog to digital converter indicating the output voltage of the sensor. The data range is between 0 and 4095. The angular position can be calculated as follows, with the 180° position defined at sensor's physical middle position. Single sensor or dual sensor can be used for rotation measurement.
2. Single sensor is mainly used for the control of robot joint with limited rotation range. The effective mechanical rotation range is 14° to 346°, corresponding to the effective electrical rotation range 0° to 332°.

$$\text{Angle position (}^\circ\text{)} = (\text{ival} - 2048) / 4095 * 333 + 180$$

3. Dual-sensor configuration is mainly used for continuous rotating joint control (such as wheels). The effective rotation range is 0° to 360°. Dual sensor configuration is only available for channel 0 and 1. By connecting two potentiometers to potentiometer channel 0 and channel 5, and specify the sensor type with command **SetDCMotorSensorUsage()** to "Dual potentiometer sensor", the channel 0 reading will combine these two sensor readings into 0° to 360° range. For channel 1, you should connect the two potentiometers to channel 1 and 4.

$$\text{Angle position (}^\circ\text{)} = (\text{ival} - 2214) / 2214 * 180 + 180$$

See also: **SetDcMotorSensorUsage()**.

III.1.9. Motor Current Sensors

```
51 short GetMotorCurrent1 ();
52 short GetMotorCurrent2 ();
53 short GetMotorCurrent3 ();
54 short GetMotorCurrent4 ();
55 short GetMotorCurrent5 ();
56 short GetMotorCurrent6 ();
57 short GetMotorCurrent (short channel);
```

Description:

GetMotorCurrentX returns the sampling value of motor current sensor.

```
Syntax: ival = GetMotorCurrent1 (); // Current sensor #1
         ival = GetMotorCurrent2 (); // Current sensor #2
```



```

ival = GetMotorCurrent3 ();           // Current sensor #3
ival = GetMotorCurrent4 ();           // Current sensor #4
ival = GetMotorCurrent5 ();           // Current sensor #5
ival = GetMotorCurrent6 ();           // Current sensor #6
ival = GetMotorCurrent (short channel); // Current sensor #1,2,3,4,5,or 6

```

Parameter: void // for GetMotorCurrentX
short channel; // 0,1,2,3,4,5 for current sensor #1,2,3,4,5,or 6
Return value: short ival;

Return data interpretation:

The return data is the raw value of the analog to digital converter indicating the motor current. The data range is between 0 and 4095. The real current can be calculated with the following formula:

$$\text{Motor Current (A)} = (\text{ival} * 3 * 375 / 200 / 4095) = \text{ival} / 728$$

III.1.10. Encoder

```

58 short GetEncoderDir1();
59 short GetEncoderDir2();
60 short GetEncoderPulse1();
61 short GetEncoderPulse2();
62 short GetEncoderSpeed1();
63 short GetEncoderSpeed2();

```

Description:

GetEncoderDirX returns +1, 0 or -1 to indicate the direction of rotation.

GetEncoderPulseX returns the current pulse counter to indicate the position of rotation.

GetEncoderSpeedX returns the current speed of rotation.

Syntax:

```

ival = GetEncoderDir1();           // direction of channel #1
ival = GetEncoderDir2();           // direction of channel #2
ival = GetEncoderPulse1();         // pulse counter of channel #1
ival = GetEncoderPulse2();         // pulse counter of channel #2
ival = GetEncoderSpeed1();         // speed of channel #1
ival = GetEncoderSpeed2();         // speed of channel #2

```

Parameter: void
Return value: short ival;

Return data interpretation:

- (1) GetEncoderDirX returns -1, 0 or 1. 1 stands for positive direction, -1 stands for negative direction, and 0 stands for no movement.
- (2) GetEncoderPulseX returns pulse counter. It is an integral value to rotation with range of 0 ~ 32767 in cycles.

- (3) `GetEncoderSpeedX` returns the rotation speed. The unit is defined as pulse change within 1 second. And it is the absolute value.

See also: `SetDcMotorSensorUsage()`.

III.1.11. Custom Analog and Digital Inputs and Outputs

```

64 short GetCustomAD1();
65 short GetCustomAD2();
66 short GetCustomAD3();
67 short GetCustomAD4();
68 short GetCustomAD5();
69 short GetCustomAD6();
70 short GetCustomAD7();
71 short GetCustomAD8();
72 short GetCustomAD (short channel);

```

Description:

GetCustomADX returns the sampling value of the custom analog to digital input signals. By default, custom AD1 - AD3 are used as the inputs of power supply voltage monitors for DSP circuits, DC motors and servo motors. User can change this setting by configuring the jumpers on PMS5005. Please refer to PMS5005 Robot Sensing and Motion Controller hardware user's manual for detailed information on hardware jumper setting.

```

Syntax:      ival = GetCustomAD1();          /* for battery of DSP circuits,
                                                or custom A/D channel #1 */
              ival = GetCustomAD2 ();      /* for battery of DC motors,
                                                or custom A/D channel #2 */
              ival = GetCustomAD3();       /* battery for servo motors,
                                                or custom A/D channel #3 */
              ival = GetCustomAD4();       // custom A/D channel #4
              ival = GetCustomAD5();       // custom A/D channel #5
              ival = GetCustomAD6();       // custom A/D channel #6
              ival = GetCustomAD7();       // custom A/D channel #7
              ival = GetCustomAD8();       // custom A/D channel #8
              ival = GetCustomAD(short channel); /* custom A/D channel #1, 2, 3, 4,
                                                5, 6, 7 or 8 */

```

```

Parameter:   void
              short channel;              /* 0, 1, 2, 3, 4, 5, 6 or 7 for
                                                channel #1, 2, 3, 4, 5, 6, 7, 8 */

```

Return value: short ival;

Return data interpretation:

The return data is the raw value of the analog to digital converter indicating the input voltage levels. The data range is between 0 and 4095. The voltage levels can be calculated from the following equation:

$$\text{Sensor output voltage} = (\text{ival}) * 3.0 / 4095 \text{ (V)}$$

See also: **GetSensorBatteryAD1~3**

73 short GetCustomDIN();

Description:

GetCustomDIN returns a value with lower 8-bits corresponding to the 8-channel custom digital inputs.

Syntax: ival = GetCustomDIN ();

Parameter: void

Return value: short ival;

Remarks:

Only lower 8-bit is valid and reflects the 8 input channel states. The MSB of the lower byte represents channel #8 and LSB of the lower byte represents channel #1.

74 void SetCustomDOUT(short ival);

Description:

SetCustomDOUT sets the 8-channel custom digital outputs.

Syntax: SetCustomDOUT (ival);

Parameter: short ival;

Return value: void

Remarks:

Only the lower 8-bit is valid and can change the corresponding outputs of the 8 channels. The MSB of the lower byte represents channel #8 and LSB of the lower byte represents channel #1.

III.2. Motion Control

This section contains the APIs for the operations of DC motors and standard RC servo motors.

The digital controlled DC motor system is depicted as the following diagram.

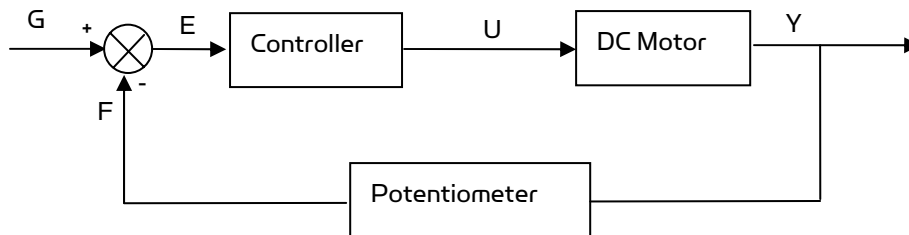

In the case of PID control, the transfer function of the PID controller looks like as:

$$U(s)/E(s) = K_p + K_D S + K_I / S$$

When using potentiometers (optical encoder and etc.) as the rotational position feedback, you have to set the motor polarity properly using "WiRobotSDK" ActiveX control API "**SetMotorPolarityX**" so that the negative feedback is achieved. See "**SetMotorPolarityX**" for detail.

The control of the standard RC servo motors is carried out by the built-in analog PID controller.

III.2.1. DC Motor Control

```

75 void SetMotorPolarity1 (short polarity);
76 void SetMotorPolarity2 (short polarity);
77 void SetMotorPolarity3 (short polarity);
78 void SetMotorPolarity4 (short polarity);
79 void SetMotorPolarity5 (short polarity);
80 void SetMotorPolarity6 (short polarity);
81 void SetMotorPolarity (short channel, short polarity);

```

Description:

SetMotorPolarityX set the motor polarity to 1 or -1 for each motor channel.

1. When the motor is running in positive direction, the potentiometer value is also increasing; motor polarity should be set to 1 which is default.
2. When the motor is running in positive direction, the potentiometer value is decreasing, motor polarity should be set to -1 or change the sensor mounting so that the potentiometer value increases.

Syntax: ival = SetMotorPolarity1 (short polarity); // Motor #1
 ival = SetMotorPolarity2 (short polarity); // Motor #2
 ival = SetMotorPolarity3 (short polarity); // Motor #3

```

ival = SetMotorPolarity4 (short polarity); // Motor #4
ival = SetMotorPolarity5 (short polarity); // Motor #5
ival = SetMotorPolarity6 (short polarity); // Motor #6
ival = SetMotorPolarity (short channel, short polarity);
// motor#1, 2, 3, 4, 5, or 6

```

Parameter: short polarity; //1 or -1
short channel; // 0, 1, 2, 3, 4, or 5 for Sonar #1, 2, 3, 4, 5, 6
Return value: void ival;

82 void EnableDcMotor (short channel);

83 void DisableDcMotor (short channel);

Description:

These functions are obsolete. Please see function ResumeDcMotor(short channel) and SuspendDcMotor(short channel).

84 void ResumeDcMotor (short channel);

85 void SuspendDcMotor (short channel);

Description:

ResumeDcMotor resumes the specified DC motor control channel.

SuspendDcMotor suspends the specified DC motor control channel. PWM output is all low.

Syntax: ResumeDcMotor (channel);
SuspendDcMotor (channel);

Parameter: short channel; // 0, 1, 2, 3, 4, or 5

Return value: void

Remarks:

1. All motor control channels are initially suspended when the system boot-up.

86 void SetDcMotorPositionControlPID (short channel, short Kp, short Kd, short Ki_x100);

87 void SetDcMotorVelocityControlPID (short channel, short Kp, short Kd, short Ki_x100);

Description:

SetDcMotorPositionControlPID sets up the PID control parameters of the specified DC motor channel for position control.

SetDcMotorVelocityControlPID sets up the PID control parameters of the specified DC motor control channel for velocity.

Syntax: SetDcMotorPositionControlPID (channel, K_p , K_d , K_i_x100);
SetDcMotorVelocityControlPID (channel, K_p , K_d , K_i_x100);

Parameter: short channel; // 0, 1, 2, 3, 4, or 5
short K_p ; // Proportional gain
short K_d ; // Derivative gain
short K_i_x100 ; // 100 times K_i (the desired Integral gain), when
 $K_i_x100 = 100$, the actual integral control term is K_i ,
= 1, K_i_x100 with range of 0 ~ 25599

Return value: void

Remarks:

1. When setting $K_i = 0$, that means **NO** integral control
2. System default value for position control: $K_p = 50$; $K_d = 5$; $K_i_x100 = 0$.
3. System default value for velocity control: $K_p = 50$; $K_d = 5$; $K_i_x100 = 0$.

See Also: **SetDcMotorControlMode**

88 void SetDcMotorTrajectoryPlan (short channel, short TrajPlanMthod);

Description:

This function is obsolete.

89 void SetDcMotorSensorFilter (short channel, short FilterMethod);

Description:

This filtering feature is still under development. All data will be treated as raw data.

90 void SetDcMotorSensorUsage (short channel, short SensorType);

Description:

SetDcMotorSensorUsage sets the sensor type for the specified DC motor control channel on the Sensing and Motion Controller (PMS5005). The available sensor types are single potentiometer, dual potentiometers, and quadrature encoder. The single potentiometer sensor is for the control of robot joint with limited rotation range (0° to 332°). The dual potentiometers and the quadrature sensor are for continuous rotating joint (like wheels) control.

Syntax: SetDcMotorSensorUsage (channel, SensorType)

Parameter: short channel; // 0, 1, 2, 3, 4, or 5 for single potentiometer sensor
// 0, 1, or 2 for dual potentiometer sensor

```

short SensorType; // 0 or 1 for quadrature encoder
                  // 0 -- Single potentiometer sensor
                  // 1 -- Dual potentiometer sensor
                  // 2 -- Quadrature encoder

```

Return value: void

Remarks:

1. The electrical angular range of the potentiometer position sensor is 0° to 332° and the corresponding mechanical rotation range is 14° to 346°, when the 180 position is defined at sensor's physical middle position.
2. Each DC motor channel for dual potentiometer sensor utilizes two potentiometer channels. DC motor channel 0 will use potentiometer channel 0 and 5; DC motor channel 1 will use potentiometer channel 1 and 4; DC motor channel 2 will use potentiometer channel 2 and 3. Please refer to the relevant application note for the use of dual potentiometers.
3. Quadrature encoder will only use DC motor channel 0 and 1.
4. System's default setting for sensor usage is single potentiometer.

See also: **GetSensorPot**

91 void SetDcMotorControlMode (short channel, short controlMode);

Description:

SetDcMotorControlMode sets the control mode of the specified DC motor control channel on the Sensing and Motion Controller (PMS5005). The available control modes are open-loop PWM control, closed-loop position control, closed-loop velocity control.

Syntax: SetDcMotorControlMode (channel, controlMode)

```

Parameter: short channel; // 0, 1, 2, 3, 4, or 5
           short controlMode; // 0 – Open-loop PWM Control
                               // 1 – Closed-loop Position Control
                               // 2 – Closed-loop Velocity Control

```

Return value: void

Remarks:

System's default setting for control mode is Open-loop PWM Control.

See also: **SetDcMotorPositionControlPID**, **SetDcMotorVelocityControlPID**

92 void DcMotorPositionTimeCtr (short channel, short cmdValue, short timePeriod);

Description:

DcMotorPositionTimeCtr sends the position control command to the specified motion control channel on the Sensing and Motion Controller (PMS5005). The command includes the target position and the target time period to execute the command. The current trajectory planning method with time control is linear.

Syntax: `DcMotorPositionTimeCtr (channel, cmdValue, timePeriod);`

Parameter: short channel; // 0, 1, 2, 3, 4, or 5
 short cmdValue; // Target position value
 short timePeriod; // Executing time in milliseconds

Return value: void

Remarks:

1. Motor will be enabled automatically by the system when this command is received.
2. Target position value is in the A/D sampling data range 0 to 4095 when using single potentiometer, 0-4428 when using dual potentiometers.
3. Please refer to the description of **GetSensorPot** for data converting between angular values and the A/D sampling data values.
4. When using encoder as sensor input, the target position value is the pulse count in the range of 0- 32767.

See also: **GetSensorPot**

93 void DcMotorPositionNonTimeCtr(short channel, short cmdValue);

Description:

DcMotorPositionNonTimeCtr sends the position control command to the specified motion control channel on the Sensing and Motion Controller (PMS5005). The command includes the target position but no time period specified to execute the command. The motion controller will drive the motor to the target position at the maximum speed.

Syntax: `DcMotorPositionNonTimeCtr (channel, cmdValue);`

Parameter: short channel; // 0, 1, 2, 3, 4, or 5
 short cmdValue; // Target position value

Return value: void

Remarks:

1. Motor will be enabled automatically by the system when this command is received.
2. Target position value is in the A/D sampling data range 0 to 4095 when using single potentiometer, 0-4428 when using dual potentiometers.
3. Please refer to the description of **GetSensorPot** for data converting between angular values and the A/D sampling data values.
4. When using encoder as sensor input, the target position value is the pulse count in the range of 0- 32767.

See also: **DcMotorPositionTimeCtr**, **GetSensorPot**

94 void DcMotorVelocityTimeCtr(short channel, short cmdValue, short timePeriods);

Description:

DcMotorVelocityTimeCtr sends the velocity control command to the specified motion control channel on the Sensing and Motion Controller (PMS5005). The command includes the target velocity and the time period to execute the command. The current trajectory planning method for time control is linear.

Syntax: DcMotorVelocityTimeCtr (channel, cmdValue, timePeriod);

Parameter: short channel; // 0, 1, 2, 3, 4, or 5
 short cmdValue; // Target velocity value
 short timePeriod; // Executing time in milliseconds

Return value: void

Remarks:

1. Motor will be enabled automatically by the system when this command is received
2. No velocity is available for motor channel using single potentiometer sensor
3. The unit of the velocity is (Position change in A/D sampling data) / second when using dual potentiometer sensor for rotational position measurement and pulse/second when using quadrature encoder.
4. Please refer to the description of **GetSensorPot** for data conversion between angular values and the A/D sampling data values.

See also: **GetSensorPot**

95 void DcMotorVelocityNonTimeCtr(short channel, short cmdValue);

Description:

DcMotorVelocityNonTimeCtr sends the velocity control command to the specified motion control channel on the Sensing and Motion Controller (PMS5005). The command includes the target velocity but no time period specified to execute the command. The motion controller will drive the motor to achieve the target velocity with maximum effort.

Syntax: DcMotorVelocityNonTimeCtr (channel, cmdValue);

Parameter: short channel; // 0, 1, 2, 3, 4, or 5
 short cmdValue; // Target velocity value

Return value: void

Remarks:

1. Motor will be enabled automatically by the system when this command is received
2. No velocity is available for motor channel using single potentiometer sensor
3. The unit of the velocity is (Position change in A/D sampling data) / second when using dual potentiometer sensor for rotational position measurement and pulse/second when using quadrature encoder.
4. Please refer to the description of **GetSensorPot** for data conversion between angular values and the A/D sampling data values.

See also: **DcMotorVelocityTimeCtr**, **GetSensorPot**

96 void DcMotorPwmTimeCtr(short channel, short cmdValue, short timePeriod);

Description:

DcMotorPwmTimeCtr sends the PWM control command to the specified motion control channel on the Sensing and Motion Controller (PMS5005). The command includes the target pulse width value and the time period to execute the command. The current trajectory planning method for time control is linear.

Syntax: DcMotorPwmTimeCtr (channel, cmdValue, timePeriod);

Parameter: short channel; // 0, 1, 2, 3, 4, or 5
 short cmdValue; // Target pulse width value
 short timePeriod; // Executing time in milliseconds

Return value: void

Remarks:

1. The specified channel (motor) will be enabled automatically by the system when this command is received
2. Target pulse width value range is 0 to 32767 (0x7FFF), corresponding to the duty cycle of 0 to 100% linearly.
3. A pulse width value of 16363 means 50% duty cycle, putting motor in "Stop" stage. Any value in between 16364 - 32767 will put the motor to turn clockwise (facing the front side of the motor) and any value in between 0 - 16362 will put the motor to turn counter-clockwise.

97 void DcMotorPwmNonTimeCtr(short channel, short cmdValue);

Description:

DcMotorPwmNonTimeCtr sends the PWM control command to the specified motion control channel on the Sensing and Motion Controller (PMS5005). The command includes the target pulse width value without specific execution time period. The motion controller will set the PWM output of this channel to the target value immediately.

Syntax: `DcMotorPwmNonTimeCtr (channel, cmdValue);`

Parameter: `short channel;` // 0, 1, 2, 3, 4, or 5
`short cmdValue;` // Target pulse width value

Return value: void

Remarks:

1. The specified channel (motor) will be enabled automatically by the system when this command is received
2. Target pulse width value range is 0 to 32767 (0x7FFF), corresponding to the duty cycle of 0 to 100% linearly.
3. A pulse width value of 16363 means 50% duty cycle, putting motor in "Stop" stage. Any value in between 16364 - 32767 will put the motor to turn clockwise (facing the front side of the motor) and any value in between 0 - 16362 will put the motor to turn counter-clockwise.

See also: **DcMotorPwmTimeCtr**

98 `void DcMotorPositionTimeCtrAll(short cmd1, short cmd2, short cmd3, short cmd4, short cmd5, short cmd6, short timePeriod);`

Description:

DcMotorPositionTimeCtrAll sends the position control command to all 6 DC motor control channels on the sensing and motion controller (PMS5005) at the same time. The command includes the target positions and the time period to execute the command. The current trajectory planning method for time control is linear.

Syntax: `DcMotorPositionTimeCtrAll (cmd1, cmd2, cmd3, cmd4, cmd5, cmd6, timePeriod);`

Parameter: `short cmd1;` // Target position for channel #1
`short cmd2;` // Target position for channel #2
`short cmd3;` // Target position for channel #3
`short cmd4;` // Target position for channel #4
`short cmd5;` // Target position for channel #5
`short cmd6;` // Target position for channel #6
`short timePeriod;` // Executing time in milliseconds

Return value: void

Remarks:

1. All DC Motors will be enabled automatically by the system when this command is received.
2. Target position value is in the A/D sampling data range 0 to 4095 when using single potentiometer, 0-4428 when using dual potentiometers.

3. Please refer to the description of **GetSensorPot** for data converting between angular values and the A/D sampling data values.
4. When using encoder as sensor input, the target position value is the pulse count in the range of 0- 32767.
5. When some motors are not under controlled, their command values should be set as -32768 (0x8000). That means NO_CONTROL.

See also: **DcMotorPositionTimeCtr**,

99 void DcMotorPositionNonTimeCtrAll(short cmd1, short cmd2, short cmd3, short cmd4, short cmd5, short cmd6);

Description:

DcMotorPositionNonTimeCtrAll sends the position control command to all 6 DC motor control channels on the Sensing and Motion Controller (PMS5005) at the same time. The command includes the target positions without specific execution time period. The motion controller will drive the motor to reach the target position with maximum effort.

Syntax: DcMotorPositionNonTimeCtrAll(cmd1, cmd2, cmd3, cmd4, cmd5, cmd6);

Parameter: short cmd1; // Target position for channel #1
short cmd2; // Target position for channel #2
short cmd3; // Target position for channel #3
short cmd4; // Target position for channel #4
short cmd5; // Target position for channel #5
short cmd6; // Target position for channel #6

Return value: void

Remarks:

1. All DC motors will be enabled automatically by the system when this command is received.
2. Target position value is in the A/D sampling data range 0 to 4095 when using single potentiometer, 0-4428 when using dual potentiometers.
3. Please refer to the description of **GetSensorPot** for data converting between angular values and the A/D sampling data values.
4. When using encoder as sensor input, the target position value is the pulse count in the range of 0- 32767.
5. When some motors are not under controlled, their command values should be set as -32768 (0x8000). That means NO_CONTROL.

See also: **DcMotorPositionNonTimeCtr**

100 void DcMotorVelocityTimeCtrAll(short cmd1, short cmd2, short cmd3, short cmd4, short cmd5, short cmd6, short timePeriods);

Description:

DcMotorVelocityTimeCtrAll sends the velocity control command to all 6 DC motor control channels on the Sensing and Motion Controller (PMS5005) at the same time. The command includes the target velocities and the time period to execute the command. The trajectory planning method for time control is linear.

Syntax: DcMotorVelocityTimeCtrAll (cmd1, cmd2, cmd3, cmd4, cmd5, cmd6, timePeriods);

Parameter: short cmd1; // Target velocity for channel #1
 short cmd2; // Target velocity for channel #2
 short cmd3; // Target velocity for channel #3
 short cmd4; // Target velocity for channel #4
 short cmd5; // Target velocity for channel #5
 short cmd6; // Target velocity for channel #6
 short timePeriod; // Executing time in milliseconds

Return value: void

Remarks:

1. Motor will be enabled automatically by the system when this command is received
2. No velocity is available for motor channel using single potentiometer sensor
3. The unit of the velocity is (Position change in A/D sampling data) / second when using dual potentiometer sensor for rotational position measurement and pulse/second when using quadrature encoder.
4. Please refer to the description of **GetSensorPot** for data conversion between angular values and the A/D sampling data values.
5. When some motors are not under controlled, their command values should be set as -32768 (0x8000). That means NO_CONTROL.

See also: **DcMotorVelocityTimeCtr**

101 void DcMotorVelocityNonTimeCtrAll(short cmd1, short cmd2, short cmd3, short cmd4, short cmd5, short cmd6);

Description:

DcMotorVelocityNonTimeCtrAll sends the velocity control command to all 6 DC motor control channels on the Sensing and Motion Controller (PMS5005) at the same time. The command includes the target velocities without specific execution time period. The motion controller will drive the motor to achieve the target velocity with maximum effort.

Syntax: DcMotorVelocityNonTimeCtrAll (cmd1, cmd2, cmd3, cmd4, cmd5, cmd6);

```

Parameter:  short cmd1;           // Target velocity for channel #1
            short cmd2;           // Target velocity for channel #2
            short cmd3;           // Target velocity for channel #3
            short cmd4;           // Target velocity for channel #4
            short cmd5;           // Target velocity for channel #5
            short cmd6;           // Target velocity for channel #6

```

Return value: void

Remarks:

1. Motor will be enabled automatically by the system when this command is received
2. No velocity is available for motor channel using single potentiometer sensor
3. The unit of the velocity is (Position change in A/D sampling data) / second when using dual potentiometer sensor for rotational position measurement and pulse/second when using quadrature encoder.
4. Please refer to the description of **GetSensorPot** for data conversion between angular values and the A/D sampling data values.
5. When some motors are not under controlled, their command values should be set as -32768 (0x8000). That means NO_CONTROL.

See also: **DcMotorVelocityNonTimeCtr**

102 void DcMotorPwmTimeCtrAll(short cmd1, short cmd2, short cmd3, short cmd4, short cmd5, short cmd6, short timePeriods);

Description:

DcMotorPwmTimeCtrAll sends the PWM control command to all 6 DC motor control channels on the Sensing and Motion Controller (PMS5005) at the same time. The command includes the target PWM values and the time period to execute the command. The current trajectory planning method for time control is linear.

```

Syntax:      DcMotorPwmTimeCtrAll (cmd1, cmd2, cmd3, cmd4, cmd5, cmd6,
                                timePeriods);

```

```

Parameter:  short cmd1;           // Target PWM value for channel #1
            short cmd2;           // Target PWM value for channel #2
            short cmd3;           // Target PWM value for channel #3
            short cmd4;           // Target PWM value for channel #4
            short cmd5;           // Target PWM value for channel #5
            short cmd6;           // Target PWM value for channel #6
            short timePeriod;     // Executing time in milliseconds

```

Return value: void

Remarks:

1. All channel (motors) will be enabled automatically by the system when this command is received

2. Target pulse width value range is 0 to 32767 (0x7FFF), corresponding to the duty cycle of 0 to 100% linearly.
3. A pulse width value of 16363 means 50% duty cycle, putting motor in "Stop" stage. Any value in between 16364 - 32767 will put the motor to turn clockwise (facing the front side of the motor) and any value in between 0 - 16362 will put the motor to turn counter-clockwise.
4. When some motors are not under controlled, their command values should be set as -32768 (0x8000). That means NO_CONTROL.

See also: **DcMotorPwmTimeCtr**

103 void DcMotorPwmNonTimeCtrAll(short cmd1, short cmd2, short cmd3, short cmd4, short cmd5, short cmd6);

Description:

DcMotorPwmNonTimeCtrAll sends the PWM control command to all 6 DC motor control channels on the Sensing and Motion Controller (PM55005) at the same time. The command includes the target PWM values without specific execution time period. The motion controller Send the desired PWM pulse width right away.

Syntax: DcMotorPwmNonTimeCtrAll (cmd1, cmd2, cmd3, cmd4, cmd5, cmd6);

Parameter: short cmd1; // Target PWM value for channel #1
 short cmd2; // Target PWM value for channel #2
 short cmd3; // Target PWM value for channel #3
 short cmd4; // Target PWM value for channel #4
 short cmd5; // Target PWM value for channel #5
 short cmd6; // Target PWM value for channel #6

Return value: void

Remarks:

1. All channel (motors) will be enabled automatically by the system when this command is received
2. Target pulse width value range is 0 to 32767 (0x7FFF), corresponding to the duty cycle of 0 to 100% linearly.
3. A pulse width value of 16363 means 50% duty cycle, putting motor in "Stop" stage. Any value in between 16364 - 32767 will put the motor to turn clockwise (facing the front side of the motor) and any value in between 0 - 16362 will put the motor to turn counter-clockwise.
4. When some motors are not under controlled, their command values should be set as -32768 (0x8000). That means NO_CONTROL.

See also: **DcMotorPwmNonTimeCtr**

III.2.2. RC Servo Motor Control

104 void EnableServo (short channel);

105 void DisableServo (short channel);

Description:

EnableServo enables the specified servo motor control channel.

DisableServo disables the specified servo motor control channel.

Syntax: EnableServo (channel);
 DisableServo (channel);

Parameter: short channel; // 0, 1, 2, 3, 4, or 5

Return value: void

Remarks:

All servo motor channels are disabled initially at system startup. They need to be enabled explicitly before use.

106 void SetServoTrajectoryPlan(short channel, short TrajPlanMthod);

Description:

This function is obsolete.

107 void ServoTimeCtr(short channel, short cmdValue, short timePeriods);

Description:

ServoTimeCtr sends the position control command to the specified servo motor control channel on the Sensing and Motion Controller (PMS5005). The command includes the target position command and the time period to execute the command. The current trajectory planning method for time control is linear.

Syntax: ServoTimeCtr (channel, cmdValue, timePeriod);

Parameter; short channel; // 0, 1, 2, 3, 4, or 5
 short cmdValue; // Target Pulse Width (ms) * 2250
 short timePeriod; // Executing time in milliseconds

Return value: void

Remarks:

1. Target position value for cmdValue = (Pulse width in millisecond) * 2250.
2. Usually, a standard remote control servo motor expects to get the specified pulse width in every 20 milliseconds in order to hold the corresponding angle position. The pulse width value in millisecond for 0°, 90° and 180° are servo manufacturer

and model dependant, they are around 1ms, 1.5ms and 2.0ms respectively for most common servos. Experiments are required to obtain the exact value which varies for different servo motors.

108 void ServoNonTimeCtr(short channel, short cmdValue);

Description:

ServoNonTimeCtr sends the position control command to the specified servo motor control channel on the Sensing and Motion Controller (PMS5005). The command includes the target position command without specific execution time period. The motion controller will send the desired pulse width to the servo motor right away.

Syntax: ServoNonTimeCtr (channel, cmdValue);

Parameter: short channel; // 0, 1, 2, 3, 4, or 5
 short cmdValue; // Target Pulse Width (ms) * 2250

Return value: void

Remarks:

Please refer to the remarks under **ServoTimeCtr**.

See also: **ServoTimeCtr**

109 void ServoTimeCtrAll(short cmd1, short cmd2, short cmd3, short cmd4, short cmd5, short cmd6, short timePeriod);

Description:

ServoTimeCtrAll sends the position control command to all 6 servo motor control channels on the Sensing and Motion Controller (PMS5005) at the same time. The command includes the target position commands and the time period to execute the command. The current trajectory planning method for time control is linear.

Syntax: ServoTimeCtrAll (cmd1, cmd2, cmd3, cmd4, cmd5, cmd6, timePeriod);

Parameter: short cmd1; // Target position for channel #1
 short cmd2; // Target position for channel #2
 short cmd3; // Target position for channel #3
 short cmd4; // Target position for channel #4
 short cmd5; // Target position for channel #5
 short cmd6; // Target position for channel #6
 short timePeriod; // Executing time in milliseconds

Return value: void

Remarks:

1. Please refer to the remarks under **ServoTimeCtr**.
2. When some servo motors are not under controlled, their command values should be set as -32768 (0x8000). That means NO_CONTROL.

See also: **ServoTimeCtr**

110 void ServoNonTimeCtrAll (short cmd1, short cmd2, short cmd3, short cmd4, short cmd5, short cmd6);

Description:

ServoNonTimeCtrAll sends the position control command to all 6 servo motor control channels on the Sensing and Motion Controller (PMS5005) at the same time. The command includes the target position commands without specific execution time period. The motion controller send the desired pulse width to the servo motor right away.

Syntax: `ServoNonTimeCtrAll(cmd1, cmd2, cmd3, cmd4, cmd5, cmd6);`

Parameter: short cmd1; // Target position for channel #1
 short cmd2; // Target position for channel #2
 short cmd3; // Target position for channel #3
 short cmd4; // Target position for channel #4
 short cmd5; // Target position for channel #5
 short cmd6; // Target position for channel #6

Return value: void

Remarks:

1. Please refer to the remarks under **ServoTimeCtr**
2. When some motors are not under controlled, their command values should be set as -32768 (0x8000). That means NO_CONTROL.

See Also: **ServoTimeCtr**

III.3. Multimedia Control

III.3.1. LCD Display

111 void LcdDisplayPMS(LPCTSTR bmpFileName);

Description:

LcdDisplayPMS displays the image data in the file *bmpFileName* (BMP format) on the graphic LCD connected to the Sensing and Motion Controller (PMS5005).

Syntax: `LcdDisplayPMS (bmpFileName);`

Parameter: LPCTSTR bmpFileName; // Full path of the BMP file for displaying
Return value: void

Remarks:

The graphic LCD display is mono with dimension of 128 pixels by 64 pixels. The bmp image must be 128x64 pixels in mono.

III.4. Events

This section documents the four Event mechanisms. When the relevant data arrive from the WiRobot PMS5005 system, relevant event will be fired, user could write his / her periodic data processing routine in the relevant event call back function.

112 StandardSensorEvent

Description:

When the standard sensor data arrive, this event will be triggered.

113 CustomSensorEvent

Description:

When the custom expansion sensor (AD and Input) data arrive, this event will be triggered.

114 MotorSensorEvent

Description:

When the motor control related sensor data arrive, this event will be triggered. The motor control data includes all the motor rotational sensor data such as potentiometer, encoder and motor current data.

IV. WiRobot SDK API Reference for PMB5010

WiRobot SDK APIs for PMB5010 supports advanced Multimedia Control features.

IV.1. Multimedia Control

This section contains the APIs for the operations of audio input and output, image capturing and LCD display.

IV.1.1. Audio Input and Output

115 void PlayAudioFile(LPCTSTR fileName);

Description:

PlayAudioFile sends an audio file (.wav format) to the Multimedia Controller (PMB5010). The file will be played back on the speaker.

Syntax: PlayAudioFile (FileName);

Parameter: LPCTSTR FileName; //the file name with full path

Return value: void

Remarks:

The .wav audio file should contain 16-bit sound wave data sampled at 8 kHz with PCM raw data format using mono channel. Other supplied wave file format will still be played by the robot but may have undesired result.

116 void StopAudioPlay ();

Description:

StopAudioPlay stops a playing audio on the Multimedia Controller (PMB5010).

Syntax: StopAudioPlay ();

Return value: void

Remarks:

There will be no effect if no audio is playing.

117 long GetVoiceSegment();

Description:

GetVoiceSegment returns the pointer to current voice data (recorded from robot microphone) in memory.

Syntax: `lpVal = GetVoiceSegment();`

Parameter: `void`

Return value: `long lpVal;` // pointer to current voice data.

Remark:

- (1) You should use method `GetVoiceSegLength()` to get the length of the Voice segment.
- (2) Voice data is in PCM raw data format with 16bit, 8KHz sampling rate.

118 `long GetVoiceSegLength();`

Description:

GetVoiceSegLength returns the length of current voice data in memory.

Syntax: `voiceLength = GetVoiceSegLength ();`

Parameter: `void`

Return value: `long voiceLength;` // Length of current voice data.

See Also: **GetVoiceSegment**

119 `void StartRecord(short voiceSegment);`

Description:

StartRecord sends start-recording command to the Multimedia Controller (PMB5010). The recorded voice data in length specified by `voiceSegment` will be stored in the shared memory segment.

Syntax: `StartRecord(voiceSegment);`

Parameter: `short voiceSegment;` // segment number for voice data, range 1-10

Return value: `void`

Remarks:

The parameter `voiceSegment` specify the time of voice segment, unit is 256 millisecond (about 1/4 sec). Value could be 1- 10. For example, if `voiceSegment` is 4, 1.024 second voice will be recorded. *VoiceSegmentEvent* event will fired when the data is ready.

120 `void StopRecord();`

Description:

StopRecord sends stop-recording command to the Multimedia Controller (PMB5010). SDK will not send recorded voice data to PC any more.

Syntax: StopRecord();

Parameter: void

Return value: void

Remarks:

There will be no effect if the Multimedia Controller is not recording.

IV.1.2. Image Capturing

121 void TakePhoto();

Description:

TakePhoto sends image capturing command to the Multimedia Controller (PMB5010). The Multimedia Controller will send back the latest frame of the image data to the WiRobot shared memory after receiving TakePhoto command. Use SavePhotoAsBMP to obtain the image.

Syntax: TakePhoto();

Parameter: void

Return value: void

Remarks:

Each TakePhoto command will get one frame of image.

122 BOOL SavePhotoAsBMP(LPCTSTR FileName);

Description:

SavePhotoAsBMP saves current frame of image data into BMP format file *FileName*.

Syntax: bVal = SavePhotoAsBMP (FileName);

Parameter: LPCTSTR FileName; // the file name with full path, for saving image data in bmp format.

Return value: BOOL bVal; // True: success
 // False: failure to save.

Remarks:

1. Before calling SavePhotoAsBMP, the TakePhoto command needs to be called to request image taken.

2. When the image data arrive, the call back event "ImageEvent" will be fired
3. The cause of "failure to save" could be caused because the TakePhoto command was not sent or the file name / path is invalid.

IV.1.3. LCD Display

123 void LcdDisplayPMB(LPCTSTR bmpFileName);

Description:

LcdDisplayPMB displays the image data in the file *bmpFileName* (BMP format) on the graphic LCD connected to the Multimedia Controller (PMB5010).

Syntax: LcdDisplayPMB (bmpFileName);

Parameter: LPCTSTR bmpFileName; // Full path of the BMP file for displaying

Return value: void

Remarks:

The graphic LCD display is mono with dimension of 128 pixels by 64 pixels. The bmp image must be 128x64 pixels in mono.

IV.2. Events

This section documents the two Event mechanisms. When the relevant data arrive from the WiRobot PMB5010 system, relevant event will be fired, user could write his / her periodic data processing routine in the relevant event call back function.

124 ImageEvent

Description:

When the image data arrive, this event will be triggered.

125 VoiceSegmentEvent

Description:

When the audio data arrive, this event will be triggered.

V. WiRobot DRK6000/8000 Specific APIs

V.1. Low Level Protection

When bumpers (optional) are installed on WiRobot RDK6000/8000 with the connection configuration shown on the right, a build-in low-level bumper collision protection scheme can be enabled or disabled with the next two commands. When this bumper protection feature is enabled:

- The wheels will stop moving forward when either bumper 0 or 1 is engaged, there will be not affect if the wheels are moving backward.
- The wheels will stop moving backward when either bumper 2 or 3 is engaged,, there will be not affect if the wheels are moving forward.
- The bumpers are connected to custom digital I/O 0, 1, 2, and 3.

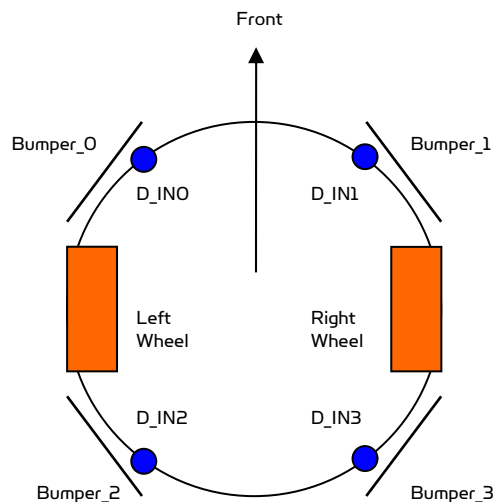

126 void EnableBumperProtection();

Description: This will enable the low level bumper protection feature.

EnableBumperProtection xxxx.

Syntax: EnableBumperProtection ();

Parameter: void;

Return value: void

Remarks:

By default, the bumper protection feature is disabled when system is booted up.

127 void DisableBumperProtection();

Description: This will disable the low level bumper protection feature.

DisableBumperProtection xxxx.

Syntax: DisableBumperProtection ();

Parameter: void;

Return value: void